

Suggested List Price Standard Equipment and Accessories

Effective: November 1, 2015



TABLE OF CONTENTS

Ordering Information	1
How to Order	1
Return Policy	1
Statement of Policy.....	1
International Equipment	1
Customer Service Department	2
Factory Contacts	2
Start-up Program	2
How to Select a Fryer	3-5
FilterQuick™ Gas Fryers	6
FilterQuick Facts.....	6
FilterQuick Gas Fryers	7
1814 Gas High Production Fryers	8
1814 Facts	8
1814.....	9,10
OCF30 Oil-Conserving Gas Fryers	11
OCF30 Oil-Conserving Gas Facts	11
OCF30ATOG and Single OCF30G.....	12
ESG35T Gas Fryer	13
ESG35T Gas Fryer.....	14
LHD65 Low Flue Temperature Gas Fryers	15
LHD65 Facts.....	15
LHD65	16
High Efficiency HD Gas Fryers	17
HD Facts	17
HD50G	18, 19
HD60G	18, 19
High Efficiency H55 Gas Fryers	20
H55 Facts	20
H55 7-Year Warranty.....	21
H55	22, 23
Performance MJ Gas Fryers	24
MJ Facts.....	24
MJ35.....	25
MJ45	26
MJCF.....	27

TABLE OF CONTENTS CONTINUED

Standard GF Gas Fryers	28
GF Facts	28
GF14	29
GF40	29
FilterQuick™ Electric Fryers	30
FilterQuick Electric Fryer Facts	30
FilterQuick Electric Fryers	31
1814 Electric High Production Fryers	32
1814 Facts	32
1814	33, 34
OCF30 Oil-Conserving Electric Fryers	35
OCF30 Facts.....	35
OCF30ATOE and Single OCF30.....	36, 37
High Efficiency RE Electric Fryers	38
RE Facts	38
RETC	39, 40
RE	41, 42
HPRE.....	43-44
Dean Decathlon (D) Gas Fryers	45
D50G	45-47
D60G	45-47
Dean Super Marathon (SM) Gas Fryers	48
SM50G	48, 49
SM5020G	48, 49
SCFSM250G	48, 49

TABLE OF CONTENTS CONTINUED

Dean Super Runner (SR) Value Gas Fryers	50
Super Runner Facts	50
SR42G	51
SR62G	51
Dean Super Runner (SRE) Value Electric Fryer	52
SR14E	52
Sandwich Holding Station	53
Food Warmers/Holding Pans/Spreaders	53
Portable Filters	54
Shortening Disposal Units	54
Frymaster Filter Accessories/Supplies	55
Filter Accessories	55
Filter Paper Chart.....	55
Dean Filter Accessories/Supplies.....	56
Filter Accessories	56
Filter Paper Chart.....	56
Pasta Cookers	57
Pasta Cooker Facts	57
Gas Pasta Cookers	58
Electric Pasta Cookers	58
Gas Fryer Accessories.....	59-62
Electric Fryer Accessories	63, 64
Dean Gas Fryer Accessories	65-67
Pasta Accessories.....	68
Product Specifications.....	69, 70
Dean Product Specifications	71
Water Bath Specifications	71
Domestic Warranty.....	72, 73
Extended Warranty	74, 75
KitchenCare	76
Appendix A: Fryer Model Guide	77, 78

ORDERING INFORMATION

HOW TO ORDER:

Manitowoc sells its Frymaster and Dean products through authorized dealers. Please contact Frymaster or your local representative. (see back cover for details.)

1. Purchase order should include the following information:
 - Company name with complete billing address and telephone number
 - Purchase order number
 - "Ship to" address
 - Purchasing agent's name
 - Requested ship date
2. Specify complete model number of equipment ordered, quantity of each item ordered, and "Order Code" for Frymaster equipment.
3. For **GAS** fryers, specify gas type (**propane, natural** or **other**). See individual fryer pages for elevation information.
4. For **ELECTRIC** fryers, specify voltage (208 volt, 240 volt, single or 3 phase) or (480 volt – 3 phase only).
5. If food warmer/holding station is ordered, specify **LOCATION** of spreader (left, right or center).
6. Specify all options, accessories and supplies – and each quantity desired.
7. Specify any special instructions.

A \$25.00 handling fee will be charged on orders of \$100.00 or less. Prices and specifications subject to change without notice. All orders accepted subject to government regulations and conditions beyond manufacturer's control.

**All shipments EXW Shreveport, Louisiana 71106 or 71129.
Equipment freight classification – Class 85 and 77.5.**

RETURN POLICY:

No merchandise returned without factory authorization. Equipment older than six months and obsolete equipment will not be an authorized return. Restocking charge minimum is 20%. Equipment built to custom specifications may be higher. Orders cancelled or changed after production has begun are subject to a minimum 20% charge.

All SHIPMENTS must be inspected immediately upon receipt and any DAMAGE must be reported to carrier. All claims must be filed by CONSIGNEE with carrier, not by or with FRYMASTER.

STATEMENT OF POLICY:

Frymaster and Dean cooking equipment is built to comply with applicable nationally recognized standards for manufacturers. Included among these approval agencies are UL, NSF, CSA and others. Many local codes exist, and it is the responsibility of the owner and installer to comply with these codes. Frymaster and Dean cooking equipment, when properly installed according to instructions, complies with the intent of the OSHA Act.

Constant product improvement makes it necessary for new or improved models to be submitted for testing by these various agencies. Therefore, not all models may have all agency approvals at all times.

INTERNATIONAL EQUIPMENT:

**Equipment for international destination is subject to additional charges.
Call Toll Free Customer Service 1-800-221-4583 for approval and quotation.**

U. S. DEALERS IN INTERNATIONAL MARKETPLACE

Definition: U.S. dealers work in the international markets either as an expansion opportunity or as a one-time situation that results from personal or direct buyer contracts. It is not our intent to actively solicit U.S. dealers as an international distribution channel. However, on occasion, it is necessary for Frymaster to service its U.S. dealer to preserve a domestic relationship.

Frymaster recognizes the importance of and supports our international Distributors to ensure proper service after the sale. For international business, equipment prices will be quoted to the U.S. dealer at U.S. dealer net plus 15%. A surcharge will be added to the 15% on European destinations for CE approved equipment. Under this contract, Frymaster assures in-country warranty and service support, documentation needed to get the job done well, and required export packaging. International warranty applies.

CUSTOMER SERVICE DEPARTMENT

CONTACT LIST FOR:

- Product Information
- Pricing
- Quotations
- Orders
- Stock Equipment

- Expedite Shipments
- Freight and Shipping Information
- Arranging Demos
- Lead Times

8700 Line Avenue, Shreveport, LA 71106
Tel: 1-800-221-4583
Tel: 1-318-865-1711
Fax: 1-318-868-5987

Email Orders: fryeqorders@manitowoc.com
Email Quotes: fryeqquotes@manitowoc.com

FACTORY CONTACTS

PARTS & WARRANTY DEPARTMENT

Tel: 1-844-724-2273
Fax: 1-318-688-2200

CREDIT DEPARTMENT

Routine statements, payment terms, billing

Tel: 1-318-865-1711
Fax: 1-318-862-2332

START-UP PROGRAM

START-UP PROGRAM:

Frymaster offers a start-up program for Frymaster and Dean fryer/filtration systems purchased through an authorized Frymaster dealer. This start-up is included with any Frymaster or Dean fryer(s) with a built-in filter. Start-up costs are not included in the purchase price of fryers without filtration, single or multiple. Start-up prices are \$200 for the first frypot and \$75 for each additional frypot.

In order to begin the start-up process you must call your Authorized Service Agent at least 48 hours in advance. The Authorized Service Agents can be found on our website at www.frymaster.com/service. The fryer system must be installed with the proper utilities hooked up. Frying oil must be on hand to properly perform the filter demonstration.

This service is offered to ensure your Frymaster or Dean Fryer System performs as advertised and to ensure your understanding of proper use of the fryers and filtration system. An FAS (Factory Authorized Servicer) technician will be on hand to personally perform the start-up service, which includes a maximum 100 miles round trip with two hours travel time.

HERE IS WHAT IS INCLUDED:

- ✓ Gas pressure check (if applicable)
- ✓ Boil out of all frypots
- ✓ Gas plumbing size (if applicable)
- ✓ Wiring inspection
- ✓ Proper basket lift operation (if applicable)
- ✓ Thorough cleaning of all frypots with a damp rag or damp paper towels to remove any oil residue or other foreign material followed by thorough drying of all frypots
- ✓ Controller check and programming demonstration (if applicable)
- ✓ Visual inspection of ventilation hood
- ✓ Demonstration of the proper use and care of the filter system

HOW TO SELECT THE FRYER THAT IS BEST FOR YOUR OPERATION

WHAT TYPE OF FRYER SHOULD I USE?

OPEN POT

The term "open pot" refers to the unobstructed heated area of the frypot. Gas fryers heat the frypot from the outside of the pot. Electric fryers have a heating element in the interior of the frypot that is immersed in the oil. Frypots are made of stainless steel.

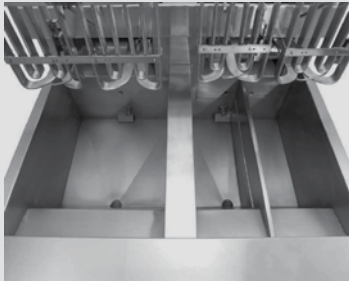

picture of open pot (FPEL214)

TUBE

Tube fryers are gas fryers that have "tubes" in the bottom area of the frypot that are permanently attached to the frypot where the tubes transfer heat to the oil in the frypot. Frypots are made of stainless steel.

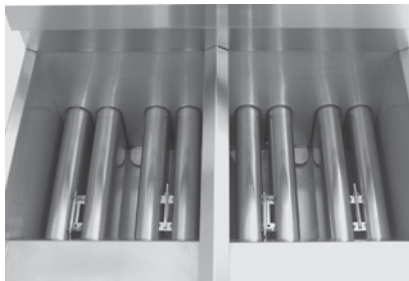

picture of tube frypot (HD60)

SEDIMENT ZONE	Open pot frypots are easy to clean but have a smaller sediment area than tube gas fryers. The open pot design allows the operator to visually monitor the amount of sediment in the bottom of the frypot.	Large sediment zone which is ideal for high sediment food product frying.
ADVANTAGES	Can be used for a broad range of low-to-medium sediment frying needs; easiest to clean. Frymaster's electric fryers have elements that swing and will stay in an up position for easier cleaning.	Can be used for a broad range of frying needs which include low sediment and higher sediment products. Easily adaptable for frying a wide range of food products and large loads.
DISADVANTAGES	Smaller sediment zone than most tube fryers; not suited for heavily breaded food products; and not ideal for specialty products.	Harder to clean than an open frypot design.
GREAT FOR FRYING	Best applications are lightly breaded (lower sediment) and freezer-to-fryer breaded product (french fries, hot wings, cheese sticks, and poppers).	Best applications are high volume and higher sediment food products.

GAS OPEN POT

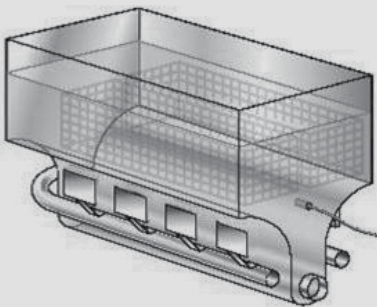

picture of gas open pot design showing cook, heat, and cold zone or sediment zone

Local utility costs will determine the cost to operate gas or electric units.

Efficiency of heat transfer depends on the type of burner
 - Infrared - high efficiency
 - Atmospheric - lower efficiency

GAS OR ELECTRIC FRYERS?

GAS TUBE

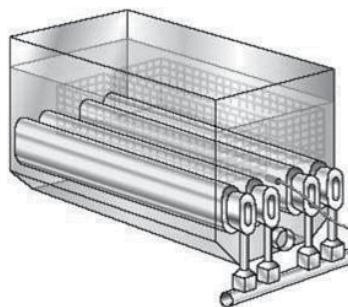

picture of gas tube frypot showing cook, heat, and cold zone or sediment zone

Local utility costs will determine the cost to operate gas or electric units.

Efficiency of heat transfer depends on tube size and baffle system
 - 6" tubes/proprietary baffles - high efficiency
 - 4" or 4" + tubes/standard baffles - lower efficiency

ELECTRIC POT

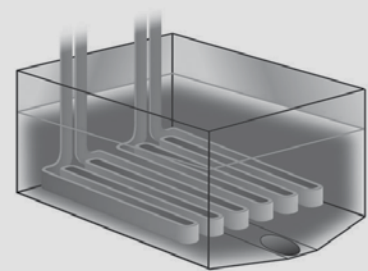







picture of electric frypot showing cook, heat, and cold zone or sediment zone

Local utility costs will determine the cost to operate gas or electric units.

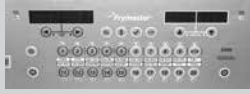
Electric units have more efficient heat transfer and faster recovery between frying cycles than gas open pot and tube units as the ribbon-type elements offer a larger surface area for heat to transfer directly into the oil.

WHAT TYPE OF CONTROLS?

Frymaster offers many different types of controllers. If you have a high volume operation and want to ensure all employees will fry consistently to the same quality specifications, then the more advanced controls that offer compensation or “stretch” cooking would be the controllers of choice.

ITEM	DESCRIPTION	COOKING PERFORMANCE	MODEL OPTIONS	PICTURE
SMART4U FILTERQUICK CONTROLLER*	Operates Fingertip semi-automated filtration. Offers push button cooking for 20 products. Times the cook operation and signals audibly when cooking is complete. Can display Fahrenheit or Celsius temperature values and stores the current time and temperature settings when the unit is turned off. Features temperature check, boil-out, melt cycle and lighted digital display. Controller operates the ATO-Automatic Top Off Oil Attendant. Controller can monitor oil management functions such as cook counts, prompt when it is time to filter, and guide workers through step-by-step oil management functions such as filtration, oil dispose and boil out. Also can be programmed for segmented cooking, used to cook bone-in chicken	Compensation or “stretch” cooking ensures the exact heat load will be utilized for each cook. The result is more consistent and higher quality food products.	FQ30U	
3000 CONTROLLER*	Operates standard built-in filtration. Offers push button cooking for 20 products. Times the cook operation and signals audibly when cooking is complete. Can display Fahrenheit or Celsius temperature values and stores the current time and temperature settings when the unit is turned off. Features temperature check, boil-out, melt cycle and lighted digital display. Controller operates the ATO-Automatic Top Off Oil Attendant. Controller can monitor oil management functions such as cook counts, prompt when it is time to filter, and guide workers through step-by-step oil management functions such as filtration, oil dispose and boil out. Also can be programmed for segmented cooking, used to cook bone-in chicken.	Compensation or “stretch” cooking ensures the exact heat load will be utilized for each cook. The result is more consistent and higher quality food products.	OCF30, 1814, LHD65, H55, H55-2, MJCFE, RE14, RE14-2, RE17, RE17-2, RE22, RE22-2, HD50G, HD60G	
CM3.5 CONTROLLER*	Smooth, touch-pad surface; multi-product programmable controller automatically stretches cook time to provide consistent food quality regardless of the product load. LEDs display cooking time countdown (with audible alarm) and provide precise frypot temperature checks. The unit also features controlled boil-out at a steady 195°F (80°C), recovery “test time”, programmable “shake” and “hold” times and more. Available for full or split-pot fryers.	Compensation or “stretch” cooking ensures the exact heat load will be utilized for each cook. The result is more consistent and higher quality food products.	OCF30, 1814, LHD65, H55, H55-2, MJ35E**, MJ45E, MJ45E-2, MJCFE**, RE14, RE14-2, RE17, RE17-2, RE22, RE22-2, RE80, HD50G, HD60G, D50G, D60G, D80G	
DIGITAL CONTROLLER	Smooth, touch-pad control panel is attractive and easy to operate. Features constant temperature display, melt cycle, lighted digital display and Fahrenheit/Celsius values.		1814, LHD65, H55, H55-2, MJ35E, MJ45E, MJ45E-2, MJCFE, RE14, RE14-2, RE17, RE17-2, RE22, RE22-2, RE80, HD50G, HD60G, D50G, D60G, D80G	
ANALOG CONTROLLER	Standard controller for many Frymaster high efficiency gas and electric fryers. Simple to operate with on/off switch, temperature set dial and melt cycle option. Works with electronic ignition.		1814, MJ35E, MJ45E, MJ45E-2, MJCFE, RE14, RE14-2, RE17, RE17-2, RE22, RE22-2	
THERMATRON CONTROLLER	Standard controller for many Dean fryers. Simple to operate with on/off switch, temperature set dial and melt cycle and boil-out options.		HD50G, HD60G, D50G, D60G, D80G, 1824, 2424	
MILLIVOLT CONTROLLER	Basic thermostat controller that gets energy from the gas flame. Requires no electrical hook-up.		ESG35T, MJ35, MJ45 MJCF GF14, GF40, SM150, SR142, SR162, SR114E	

* Basket lifts only available with CM3.5, 3000 and FilterQuick controllers.

** CM3.5 controller available with filtration models only.

BUILT-IN FILTER SYSTEM ANNUAL OIL SAVINGS

NO FILTERING

Oil life will be very short and cost of oil replacement will dramatically increase the cost of ownership.

PORTABLE FILTER

Oil life will be extended and reduce cost of ownership over not filtering oil. Portable filtering can be very time consuming and labor intensive.

BUILT-IN FILTERING SYSTEM

A built-in filtering system will provide the maximum oil life which will dramatically reduce the cost of ownership. Filtering is much less labor intensive than utilizing portable filtration units. Filtering can also be done quickly and easily when required.

NUMBER OF 50-LB. FRYPOTS FILTERED	STANDARD OIL			TRANS FAT-FREE OIL		
	ANNUAL OIL COSTS WITH NO FILTRATION	ANNUAL COST WITH FILTRATION*	ANNUAL PAYBACK	ANNUAL OIL COSTS WITH NO FILTRATION	ANNUAL COST WITH FILTRATION*	ANNUAL PAYBACK
1	\$2,600	\$1,300	\$1,300	\$3,900	\$1,950	\$1,950
2	\$5,200	\$2,600	\$2,600	\$7,800	\$3,900	\$3,900
3	\$7,800	\$3,900	\$3,900	\$11,700	\$5,850	\$5,850
4	\$10,400	\$5,200	\$5,200	\$15,600	\$7,800	\$7,800
5	\$13,000	\$6,500	\$6,500	\$19,500	\$9,750	\$9,750
6	\$15,600	\$7,800	\$7,800	\$23,400	\$11,700	\$11,700

*Savings based on the following: Oil costs of \$.50/lb. for standard oil and \$.75/lb. for trans fat-free oil. Oil changed 2x/week without filtration and 1x/week with filtration.

ENERGY STAR ANNUAL ENERGY SAVINGS

NON ENERGY STAR UNITS

Lower cost of purchasing but higher cost of ownership. Pay less upfront and more to operate the fryer during its lifetime.

ENERGY STAR UNITS

Higher cost of purchasing but lower cost of ownership. Pay more upfront and less to operate the fryer during its lifetime.

MODEL	SR52* PER POT	HD50** PER POT	H55** PER POT
BTU/HR. INPUT	120k	95k	80k
OIL CAPACITY (LBS.)	50	50	50
LBS. FRIES/HR	65	70	70
ENERGY COST/YR	\$2,579	\$1,738	\$1,507
OIL COST/YR. @ \$.75/LB.	\$5,942	\$3,992	\$3,992
ANNUAL COST/YR	\$8,521	\$5,730	\$5,499
ANNUAL SAVINGS	Per Pot	\$2,791 (33%)	\$3,022 (35%)

Saving Potential: \$3,000 + per year / pot!

NEW!



FilterQuick® With Automatic Filtration and Optional Oil Quality Sensor

Gas Fryers



Fingertip Filtration Plus:
40% Less Oil, 10% Less Energy, Outstanding Results

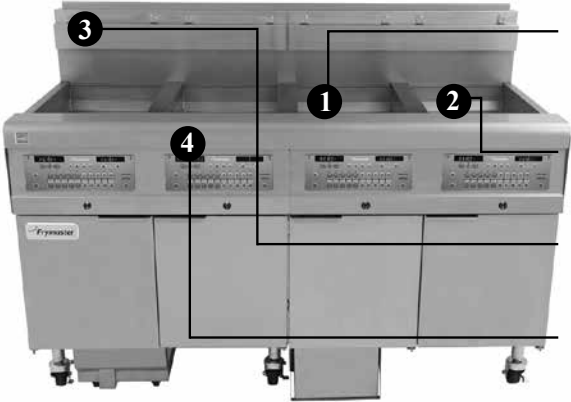

1. **30-lb. open frypot design** requires 40% less oil and ensures quick and easy cleaning. Saves money, time and labor.
2. **Independent frypot construction** allows convenient frypot repairs in the field, if needed.
3. **State-of-the-art combustion** fuels efficiency. Infrared heat transfer qualifies fryers for energy-saving rebates.
4. **SMART 4U® FilterQuick Controller** has operation management features that monitor and help control food and oil quality, oil life, and equipment performance. Has 20 programmable cook buttons and auto adjusts cook time to load size.

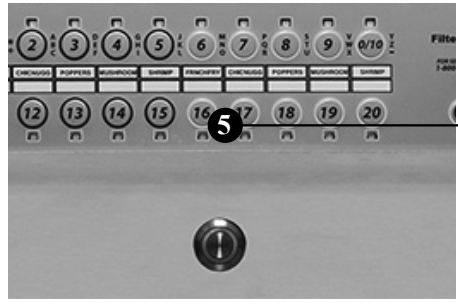

5. **Fingertip, closed cabinet, full-automatic filtration** starts with push-button ease. It makes caring for the oil and optimizing food quality simple.
 - Safe technology ensures only one frypot can drain at a time. Filtration is as easy as pushing a button.
 - The filter pump agitates the oil in the frypot before draining to lift the crumbs from the bottom of the frypot, aiding their removal.
 - The blower cools the frypot when draining.
 - The frypot begins heating as soon as a safe level of oil returns to the frypot to speed return to set temperature.
 - The pump is protected from bulk oil connection dead heading.

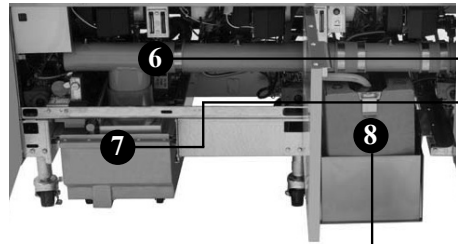

6. **Optional oil quality sensor** monitors the oil's health and advises when to discard. No more guesswork.
7. **Innovative safety features** offer proprietary advantages over other fryers – prevent simultaneous vat filtrations.
8. **Oil Attendant® auto fill feature** senses the oil level and adds oil as needed from an in-cabinet supply.

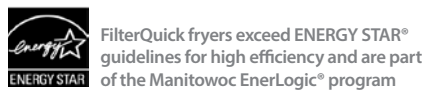

OIL-CONSERVING FILTERQUICK GAS FRYERS WITH FULLY-AUTOMATIC FILTRATION

FILTERQUICK FRYER BATTERIES WITH FILTRATION, AUTO TOP-OFF, STAINLESS STEEL FRYPOTS, DOORS AND CABINET

MODEL NUMBER	OIL MANAGEMENT PACKAGE*	OIL CAPACITY LBS	COOK AREA W" x L" x D"	BTU/HR INPUT	SHIPPING WEIGHT LBS
2FQG30U FULL POT	\$37,099	(2) 30	(2) 13 x 14 x 3-3/4	(2) 75,000	544
3FQG30U FULL POT	\$49,449	(3) 30	(3) 13 x 14 x 3-3/4	(3) 75,000	723
4FQG30U FULL POT	\$61,799	(4) 30	(4) 13 x 14 x 3-3/4	(4) 75,000	908
5FQG30U FULL POT	\$74,149	(5) 30	(5) 13 x 14 x 3-3/4	(5) 75,000	1,089

*Standard with FilterQuick controller.

NOTES:

- Split frypots - Add \$2,500 for each split frypot.
- Basket Lifts - Add \$2,500 for each frypot (full or split).
- Casters included in pricing.
- Tandem basket lifts - Add \$80 each frypot (full or split).

STANDARD ACCESSORIES

FilterQuick Filtration with ATO Casters Rack-type Basket Support Bottom Splash Shield	Basket Hanger Twin Baskets Filter Starter Kit Oil Management Package*
--	--

FRYER ACCESSORIES

Basket, full size 12-3/8 x 12-7/8 x 5-1/4 Part No. 8030099 (can't be used w/ basket lifts)	\$244	Cover, stainless steel Split Pot 7-1/4 W x 21 D Part No. 1068931	\$131
Basket, triplet 4-1/4 x 13-1/4 x 5-1/2 Part No. 8030438	\$159	Elevated Top-Off Container Kit	\$748
Basket, twin size 5-7/8 x 12-5/8 x 6-5/8 Part No. 8030271	\$163	Fish Plate - full pot 12" X 13-3/8" X 3/8" Part No. 8238066	\$337
Basket Hanger, single frypot; 15-3/8 W x 5 H Part No. 2308165	\$89	Fish Scoop 8-1/8 W x 8-1/2 D w/ 17-3/8 handle Part No. 8030059	\$96
Basket Hanger, 2 & 4 frypots; 31 W x 5 H Part No. 2307495 (2 hangers required for 4 frypots)	\$179	Fish Skimmer 6" square w/ insulated handle Part No. 8030184	\$87
Basket Hanger, 3 frypots; 46-1/2 W x 5 H Part No. 2307497	\$268	Fish Skimmer - no hooks 6" square w/ insulated handle Part No. 8030446	\$87
Basket Hanger, 5 frypots; 31 W x 5 H & 46-1/2 W x 5 H 1 Part No. 2307497 1 Part No. 2307495	\$447	Jug in Box (JIB) Holder - stainless steel (not NSF approved); 10-1/2 x 10-1/2 x 8-1/2; Part No. 8242298	\$282
Basket Support Rack - full pot 11-7/8 W x 13-1/2 D Part No. 8030375	\$93	Jug in Box (JIB) Holder Mobile Part No. 8239145	\$195
Basket Support Rack - split pot 5-7/8 W x 13-1/2 D Part No. 8030372	\$83	Quick Disconnect Hose 1" gas line, 36" long Part No. 8061698	\$604
Brush, L-shaped Tampico 21" L x 2" Diameter Part No. 8030429	\$65	Quick Disconnect Hose 1" gas line, 48" long Part No. 8061699	\$648
CASTERS - set of four Call Customer Service to specify model	\$284	Sediment tray - full pot 11-7/8 x 15-1/4 x 6-1/2 Part No. 8030382	\$441
Chicken/Fish Tray - full pot 12 W x 13-3/8 D Part No. 8238859	\$337	Splash Shield, Side 19-1/2 W x 11-3/4 H Part No. 8238224	\$113
Clean-out Rod 26" long Part No. 8030388	\$83	Splash Shield, Bottom	\$41/frypot
Cover, stainless steel - full pot 14-5/8 W x 21 D Part No. 1068930	\$220		

NOTES:

- 5 ft. grounded cordset provided.
- If elevation is between 5,000 - 10,000 feet, specify the elevation level. Fryer may not perform at optimum levels above this elevation.
- **DO NOT CURB MOUNT.**
- Any questions or pricing information other than the above should be referred to **CUSTOMER SERVICE -- TOLL FREE 1-800-221-4583.**

SPECIAL OIL OPTIONS

SEMI-SOLID / SOLID SHORTENING	\$2,331
FRONT OIL DISCHARGE (Precludes bulk rear oil discharge)	MUST BE SPECIFIED WHEN ORDERED
OIL QUALITY SENSOR	\$2,299

SPREADERS - ADD TO PRICE OF FRYER BATTERY

SPREADER CABINET Call Customer Service for availability and placement.	\$999
---	-------

FILTERING ACCESSORIES

Filter Powder (80, 1oz. Packs) Part No. 8030002	\$100
Filter Paper (16-1/2 x 25-1/2); Box of 100 sheets Part No. 8030445	\$119
Metal Filter Screen * (for built-in filtration) (11-1/8 x 19-1/4)	\$682

FRYMASTER GAS LINE INFORMATION

1-1/2" gas supply line required. Battered units (2 or more) require 1" NPT connection Gas inlet size (I.D.) should be no smaller than that provided for connection to the fryers. See service manual and/or plumbing codes for proper pipe sizing.

*Oil Management Package included at no extra charge.

Includes:

- Set-up for bulk oil
- Frypot covers

Now With
Expanded
Model
Options!

Frymaster

1814 High-Production, Oil-Conserving, Gas Fryers

Conserve Oil, Energy, & Space

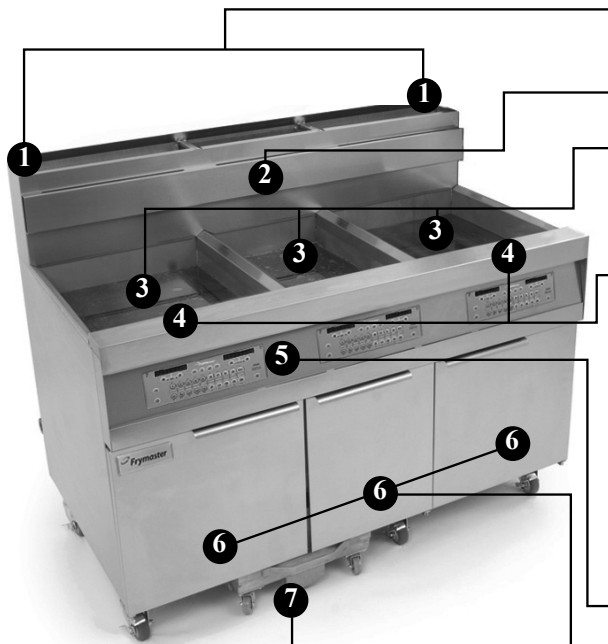

Model shown: 11814/HD50G/11814

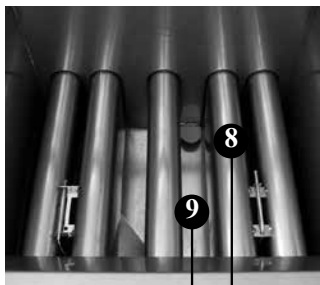

1. **Use 11-15% less hood and floor space** than standard fryer systems.
2. **Use upwards of 50% less energy** than comparable standard fryer systems.
3. **Use less oil** reducing operating costs and environmental impact.
 - **16-20% less** than 3 standard 50-lb fryers (126 lbs of oil vs 150 lbs)
 - **12-14% less** than 4 standard 50-lb fryers (176 lbs of oil vs 200 lbs)
4. **Deliver flexible, high-production cooking** with one or two 18" x 14" x 3-3/4" cooking area(s) that can cook three baskets of food at the same time. Each 18" x 14" x 3-3/4" frypot can produce:
 - **118 lbs.** of frozen chicken nuggets/hr
 - **100 lbs.** of French fries/hr
 - **74 lbs.** of fresh-breaded chicken strips/hr
 - **68 lbs.** of dry dredge catfish/hr
 - **96 pieces** of fresh-breaded, 8-piece cut chicken/hr
 - **77 lbs.** of wings/hr (875 pieces)
5. **Control food and oil quality with the SMART4U® 3000 controller**, which has programmable cook buttons and features that make it easy to produce consistent, great-tasting food. Digital* and CM3.5*controller options are also available.
6. **Save on equipment costs.**
 - Two 1814 fryers do the work of three 50-lb fryers.
 - Two 1814 & one HD50 do the work of four 50-lb fryers.
7. **Support oil station management** with built-in filtration options, making it easy to preserve oil life and ensure consistent, great-tasting food. 8 GPM pump quickly removes crumbs and sediment, making the filter process quick and effective.
8. **Optimize heat transfer** with 6" vs. 4" diameter tubes, which provide a 36% larger surface for oil contact.
9. **Handle high-sediment foods with ease.** Sloping bottom ensures fast drainage and easy cleaning.



All 1814 models meet ENERGY STAR® guidelines and are part of the Manitowoc EnerLogic® energy program.

*Not available for CE.

HIGH-PRODUCTION OIL-CONSERVING 1814 GAS TUBE FRYERS

1814 FRYERS WITHOUT FILTRATION WITH STAINLESS STEEL FRYPOT, DOOR AND CABINET SIDES							
MODEL NUMBER	DIGITAL	CM3.5 CONTROLLER	SMART4U 3000 CONTROLLER	OIL CAPACITY LBS	COOK AREA W" x L" x D"	BTU/HR INPUT	SHIPPING WEIGHT LBS
11814G	\$10,049	\$11,249	\$11,949	63	18 x 14 x 3-3/4	119,000	255

* Standard with SMART4U 3000 controller.

1814 FRYERS WITH FILTRATION STAINLESS STEEL FRYPOT(S), DOOR(S) AND CABINET SIDES							
MODEL NUMBER	DIGITAL	CM3.5 CONTROLLER	SMART4U 3000 CONTROLLER	OIL CAPACITY LBS	COOK AREA W" x D" x H"	BTU/HR INPUT	SHIPPING WEIGHT LBS
11814GF	\$20,649	\$21,849	\$22,549	63	18 x 14 x 3-3/4	119,000	390
21814GF	\$31,749	\$34,149	\$35,549	(2) 63	(2) 18 x 14 x 3-3/4	(2) 119,000	645
31814GF	\$42,799	\$46,399	\$48,499	(3) 63	(3) 18 x 14 x 3-3/4	(3) 119,000	900
41814GF	\$53,899	\$58,699	\$61,499	(4) 63	(4) 18 x 14 x 3-3/4	(4) 119,000	1,155
11814/HD50G/11814 (W/ FILTER)	\$41,049	\$44,349	\$45,849	(2) 63 (1) 50	(2) 18 x 14 x 3-3/4 (1) 14 x 14 x 3-1/2	(2) 119,000 (1) 100,000	907

* Standard with SMART4U 3000 controller.

STANDARD ACCESSORIES	
Electronic Ignition	Filter models have:
Twin Baskets	Drain Safety Switch
Rack-type Basket Supports	Filter Starter Kit
Basket Hangers	Casters
Legs (non-filter models)	8GPM Pump

HIGH-PRODUCTION OIL-CONSERVING 1814 GAS TUBE FRYERS

FRYER ACCESSORIES			
Basket, twin size 5-7/8 x 12-5/8 x 6-5/8 Part No. 8030271	\$163	Cover, stainless steel - full pot, HD50G 13-1/2 W x 21-3/8 D Part No. 1061637	\$239
Basket, chicken 17-3/4 x 12-1/4 x 6 Part No. 8030436	\$461	Fish Plate - full pot 11814 - 18 W x 13-5/8 D Part No. 2208966	\$344
Basket, dual 8 x 12-5/8 x 7 Part No. 8030437	\$166	Fish Plate - full pot HD50G - 13-5/8 W x 13-1/2 D Part No. 2208963	\$337
Basket, full size 17-1/2 x 12-7/8 x 6-1/8 Part No. 8030435	\$252	Fish Scoop 8-1/8 W x 8-1/2 D w/ 17-3/8 handle Part No. 8030059	\$96
Basket, quad 4-1/2 x 13-1/4 x 6 Part No. 8030357	\$159	Fish Skimmer 6" square w/ insulated handle Part No. 8030184	\$87
Basket Hanger 11814 20 W x 8-1/2 H Part No. 8237770	\$89	Foam Deck Basket Banger* Part No. 2600623	\$190/frypot
Basket Hanger 21814 39-3/4 W x 8-1/2 H Part No. 8237771	\$179	Legs - set of four (non-filter models only)	\$284
Basket Hanger - 11814/HD50G/11814 55-1/4 W x 8-1/2 H Part No. 8237772	\$268	Quick Disconnect Hose 1" gas line, 36" long Part No. 8061698	\$604
Basket Support Rack Full pot, 1814 13-5/8 W x 18 D Part No. 8030380	\$111	Quick Disconnect Hose 1" gas line, 48" long Part No. 8061699	\$648
Basket Support Rack Full pot, HD50 13-1/2 W x 13-1/4 D Part No. 8030273	\$91	Quick Disconnect Hose 3/4" gas line, 36" long Part No. 8061701	\$491
Brush, L-shaped Tampico 21" L x 2" Diameter Part No. 8030429	\$65	Quick Disconnect Hose - 3/4" gas line, 48" long Part No. 8061700	\$535
CASTERS - set of four	\$284	Sediment Tray 17-3/4 x 13-5/8 x 11 Part No. 1086187	\$494
Clean-out Rod 27" long Part No. 8030197	\$83	Splash Shield 21-3/8 D x 7-7/8 H Part No. 8237619	\$246
Cover, stainless steel - full pot, 11814 21-3/8 W x 19-1/2 D Part No. 1081872	\$239	Top Connecting Strip Part No. 2102681	\$139

* If ordered after purchase, requires changing of top connecting strips.

NOTES:

- If elevation is between 2,000 - 6,000 feet, specify the elevation level. Fryer may not perform at optimum levels above this elevation.
- **DO NOT CURB MOUNT.**
- Any questions or pricing information other than the above should be referred to **CUSTOMER SERVICE -- TOLL FREE 1-800-221-4583.**

EXTERNAL OIL DISCHARGE OPTIONS	
External oil discharge - available on built-in filter batteries of 2 or more frypots. Must specify front or rear connection. Front connection comes with 5' washdown hose	Front \$1,593
	Rear \$1,082
External oil discharge kit (rear only) - available on batteries with filter*	CALL KITCHENCARE AT 1-844-724-2273
Bulk oil (dispose and fresh fill) on batteries with built-in filtration	\$2,000

* Requires field service installation

SPREADERS - ADD TO PRICE OF FRYER(S)	
SPREADER CABINET Call Customer Service for availability and placement.	\$1,599

FILTERING ACCESSORIES	
Filter Powder (80, 1oz. Packs) Part No. 8030002	\$100
Filter Paper (22 x 34) Box of 100 sheets Part No. 8030289	\$217
Filter Screen (high sediment) 8-1/4 W x 14 D Part No. 8239116	\$299

FRYMASTER GAS LINE INFORMATION	
1-1/2" gas supply line required. Each single unit requires a 3/4" NPT connection; battered units (2 or more) require a 1" NPT connection. Gas inlet size (I.D.) should be no smaller than that provided for connection to the fryers. See service manual and/or plumbing codes for proper pipe sizing.	

OCF30

OIL CONSERVING FRYERS

OCF30™ Series Gas Fryers

40% Less Oil, 10% Less Energy, Outstanding Results

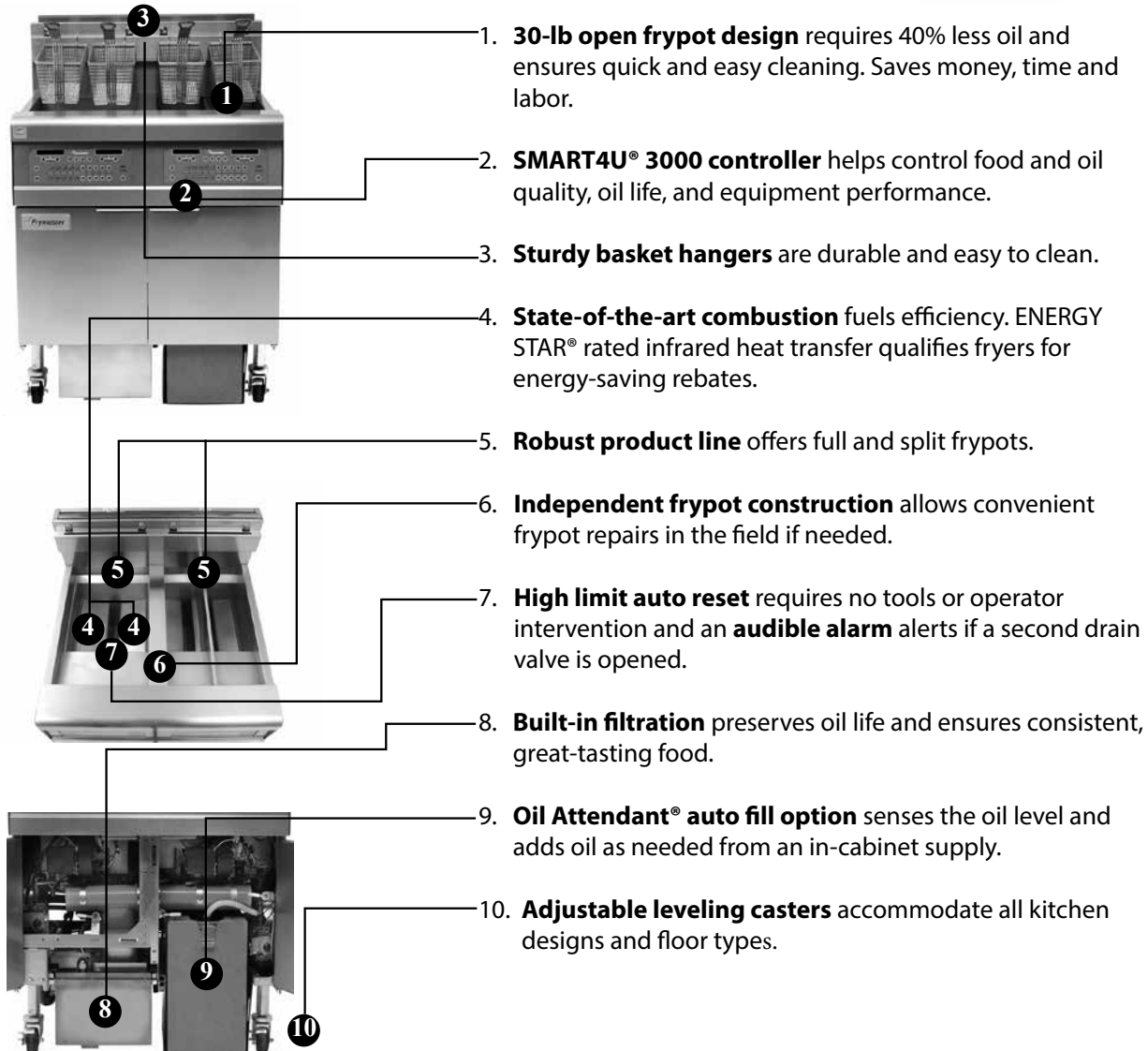

1. **30-lb open frypot design** requires 40% less oil and ensures quick and easy cleaning. Saves money, time and labor.
2. **SMART4U® 3000 controller** helps control food and oil quality, oil life, and equipment performance.
3. **Sturdy basket hangers** are durable and easy to clean.
4. **State-of-the-art combustion** fuels efficiency. ENERGY STAR® rated infrared heat transfer qualifies fryers for energy-saving rebates.
5. **Robust product line** offers full and split frypots.
6. **Independent frypot construction** allows convenient frypot repairs in the field if needed.
7. **High limit auto reset** requires no tools or operator intervention and an **audible alarm** alerts if a second drain valve is opened.
8. **Built-in filtration** preserves oil life and ensures consistent, great-tasting food.
9. **Oil Attendant® auto fill option** senses the oil level and adds oil as needed from an in-cabinet supply.
10. **Adjustable leveling casters** accommodate all kitchen designs and floor types.



OCF30G fryers meet ENERGY STAR® guidelines for high efficiency, and all OCF30G fryers are part of the Manitowoc EnerLogic® program.

OIL-CONSERVING OCF30 GAS FRYERS

OCF30 FRYERS WITH FILTRATION, MANUAL TOP-OFF STAINLESS STEEL FRYPOT, DOOR AND CABINET					
MODEL NUMBER	SMART4U 3000 CONTROLLER*	OIL CAPACITY LBS	COOK AREA W" x L" x D"	BTU/HR INPUT	SHIPPING WEIGHT LBS
FPGL130C FULL POT	\$19,549	30	13 x 14 x 3-3/4	75,000	265

OCF30 FRYER BATTERIES WITH FILTRATION, AUTO TOP-OFF STAINLESS STEEL FRYPOTS, DOORS AND CABINET					
MODEL NUMBER	SMART4U 3000 CONTROLLER*	OIL CAPACITY LBS	COOK AREA W" x D" x H"	BTU/HR INPUT	SHIPPING WEIGHT LBS
FPGL230CA FULL POT	\$33,999	(2) 30	(2) 13 x 14 x 3-3/4	(2) 75,000	544
FPGL330CA FULL POT	\$46,349	(3) 30	(3) 13 x 14 x 3-3/4	(3) 75,000	723
FPGL430CA FULL POT	\$58,699	(4) 30	(4) 13 x 14 x 3-3/4	(4) 75,000	908
FPGL530CA FULL POT	\$71,049	(5) 30	(5) 13 x 14 x 3-3/4	(5) 75,000	1,077

* Standard with SMART4U 3000 controller.

NOTES:

- Split frypots - Add \$2,500 for each split frypot.
- Basket Lifts - Add \$2,500 for each full frypot.
- Casters included in pricing.
- Can substitute CM3.5 for 3000 controller for no additional cost (FPGL130C only).
- Tandem basket lifts - Add \$80 each frypot (full or split).

FRYER ACCESSORIES			
Basket, full size 12-3/8 x 12-7/8 x 5-1/4 Part No. 8030099 (can't be used w/ basket lifts)	\$244	Cover, stainless steel - full pot 14-5/8 W x 21 D Part No. 1068930	\$220
Basket, triplet 4-1/4 x 13-1/4 x 5-1/2 Part No. 8030438	\$159	Cover, stainless steel Split Pot 7-1/4 W x 21 D Part No. 1068931	\$131
Basket, twin size 5-7/8 x 12-5/8 x 6-5/8 Part No. 8030271	\$163	Fish Plate 12" X 13-3/8" X 3/8" Part No. 8238066	\$337
Basket Hanger, single frypot; 15-3/8 W x 5 H Part No. 2308165	\$89	Fish Scoop 8-1/8 W x 8-1/2 D w/ 17-3/8 handle Part No. 8030059	\$96
Basket Hanger, 2 & 4 frypots; 31 W x 5 H Part No. 2307495 (2 hangers required for 4 frypots)	\$179	Fish Skimmer 6" square w/ insulated handle Part No. 8030184	\$87
Basket Hanger, 3 frypots; 46-1/2 W x 5 H Part No. 2307497	\$268	Jug in Box (JIB) Holder - stainless steel (not NSF approved); 10-1/2 x 10-1/2 x 8-1/2; Part No. 8242298	\$282
Basket Hanger, 5 frypots; 31 W x 5 H & 46-1/2 W x 5 H 1 Part No. 2307497 1 Part No. 2307495	\$447	Jug in Box (JIB) Holder Mobile Part No. 8239145	\$195
Basket Support Rack - full pot 11-7/8 W x 13-1/2 D Part No. 8030375	\$93	Quick Disconnect Hose 1" gas line, 36" long Part No. 8061698	\$604
Basket Support Rack - split pot 5-7/8 W x 13-1/2 D Part No. 8030372	\$83	Quick Disconnect Hose 1" gas line, 48" long Part No. 8061699	\$648
Brush, L-shaped Tampico 21" L x 2" Diameter Part No. 8030429	\$65	Sediment tray - full pot 11-7/8 x 15-1/4 x 6-1/2 Part No. 8030382	\$441
CASTERS - set of four	\$284	Splash Shield 19-1/2 W x 11-3/4 H Part No. 8238224	\$113
Chicken/Fish Tray - full pot 12 W x 13-3/8 D Part No. 8238859	\$337	Top Connecting Strip FPGL130 Part No. 8235810	\$139
Clean-out Rod 27" long Part No. 8030197	\$83		

NOTES:

- 5 ft. grounded cord set provided.
- If elevation is between 5,000 - 10,000 feet, specify the elevation level. Fryer may not perform at optimum levels above this elevation.
- **DO NOT CURB MOUNT.**
- Any questions or pricing information other than the above should be referred to **CUSTOMER SERVICE -- TOLL FREE 1-800-221-4583.**

STANDARD ACCESSORIES	
Built-in Filtration with ATO Casters Rack-type Basket Support ATO (except FPGL130C)	Basket Hanger Twin Baskets Filter Starter Kit

SPECIAL OIL OPTIONS	
BULK OIL (REAR ONLY)	\$2,000
BULK OIL KIT (REAR ONLY) *	CALL KITCHENCARE AT 1-844-724-2273
SEMI-SOLID / SOLID SHORTENING	\$2,331

* Requires field service installation

SPREADERS - ADD TO PRICE OF FRYER (\$)	
SPREADER CABINET Call Customer Service for availability and placement.	\$999

FILTERING ACCESSORIES	
Filter Powder (80, 1oz. Packs) Part No. 8030002	\$100
Filter Paper (19-1/2 x 27-1/2); Box of 100 sheets Part No. 8030170	\$119
Metal Filter Screen * (for built-in filtration) (11-1/8 x 19-1/4)	\$682

FRYMASTER GAS LINE INFORMATION	
1-1/2" gas supply line required. Battered units (2 or more) require 1" NPT connection Gas inlet size (I.D.) should be no smaller than that provided for connection to the fryers. See service manual and/or plumbing codes for proper pipe sizing.	



ESG35T ENERGY STAR® Value, High-Efficiency Fryer

Saves Energy and Oil.

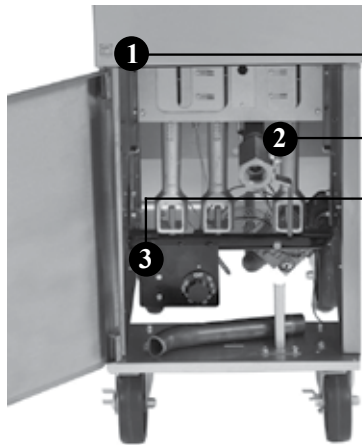

- 1. **High-efficiency.** Exceeds ENERGY STAR® guidelines and qualifies for energy saving rebates.
- 2. **Requires 33% less BTU/hr** than comparable standard models.
- 3. **Millivolt Control** - no electrical hook-up required.

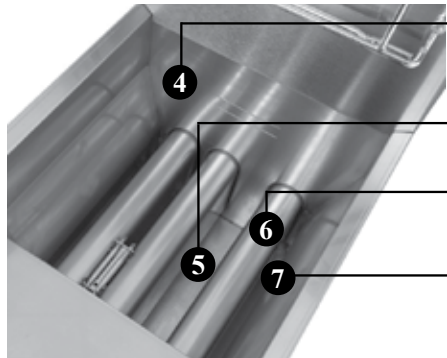

- 4. **22% less oil.** 35-lb. frypot produces as much food as a 45-lb. fryer.
- 5. **Wide cold zone** keeps crumbs and sediment away from cooking areas.
- 6. **6-inch heating tubes** along with a proprietary baffle design deliver superior heat transfer.
- 7. **Insulated frypot** allows for a low idle rate further enhancing energy savings.



- 8. **Reduced flue heat.** 27% Less.
- 9. **Stainless steel** frypot, front door, backsplash and flue.



ESG35T fryers meet ENERGY STAR® guidelines for high efficiency and are part of the Manitowoc EnerLogic® program

ESG35T ENERGY STAR® VALUE GAS FRYER

ESG35T FRYERS WITHOUT FILTRATION, WITH STAINLESS STEEL FRYPOT, DOOR, AND ALUMINIZED SIDES					
MODEL NUMBER	MILLIVOLT CONTROLLER	OIL CAPACITY LBS	COOK AREA W" x L" x D"	BTU/HR INPUT	SHIPPING WEIGHT LBS
ESG35T	\$2,999	35	14 x 13-3/4 x 4-1/5	70,000	165

NOTES:

- Piezo ignitor - Add \$109.

FRYER ACCESSORIES			
Basket, twin size 5-7/8 x 12-5/8 x 6-5/8 Part No. 8030271	\$163	CASTERS - set of four	\$284
Basket Hanger 12-1/2 W x 3-3/4 H Part No. 8102793	\$98	Clean-out Rod 26" long Part No. 8030197	\$83
Basket Support Rack 13-1/2" W x 11-1/4" D Part No. 8030442	\$87	Cover, frypot 13-1/2 W x 21-3/8 D Part No. 1061637SP	\$239
Brush, L-shaped Tampico 21" L x 2" Diameter Part No. 8030429	\$65	Legs - 6" H, set of four	\$284
Brush, L-shaped Teflon 26-3/4" L x 1" Diameter Part No. 8030278	\$78		

STANDARD ACCESSORIES	
Legs Rack-type Basket Support	Basket Hanger Twin Baskets

FRYMASTER GAS LINE INFORMATION
Fryers must be installed with proper size gas line. Each single unit requires a 3/4" NPT connection.

NOTES:

- **CALL CUSTOMER SERVICE -- TOLL FREE 1-800-221-4583** or refer to manual provided with fryer for correct sizing information including high elevation installations.
- If elevation is between 2,000 - 6,000 feet, specify the elevation level. Fryer may not perform at optimum levels above this elevation.
- **DO NOT CURB MOUNT.**
- Any questions or pricing information other than the above should be referred to **CUSTOMER SERVICE -- TOLL FREE 1-800-221-4583.**



LHD65 Low Flue Temperature Gas Fryers

Keep the Kitchen Cool and Production Capacity High

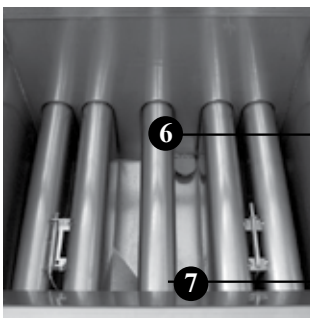
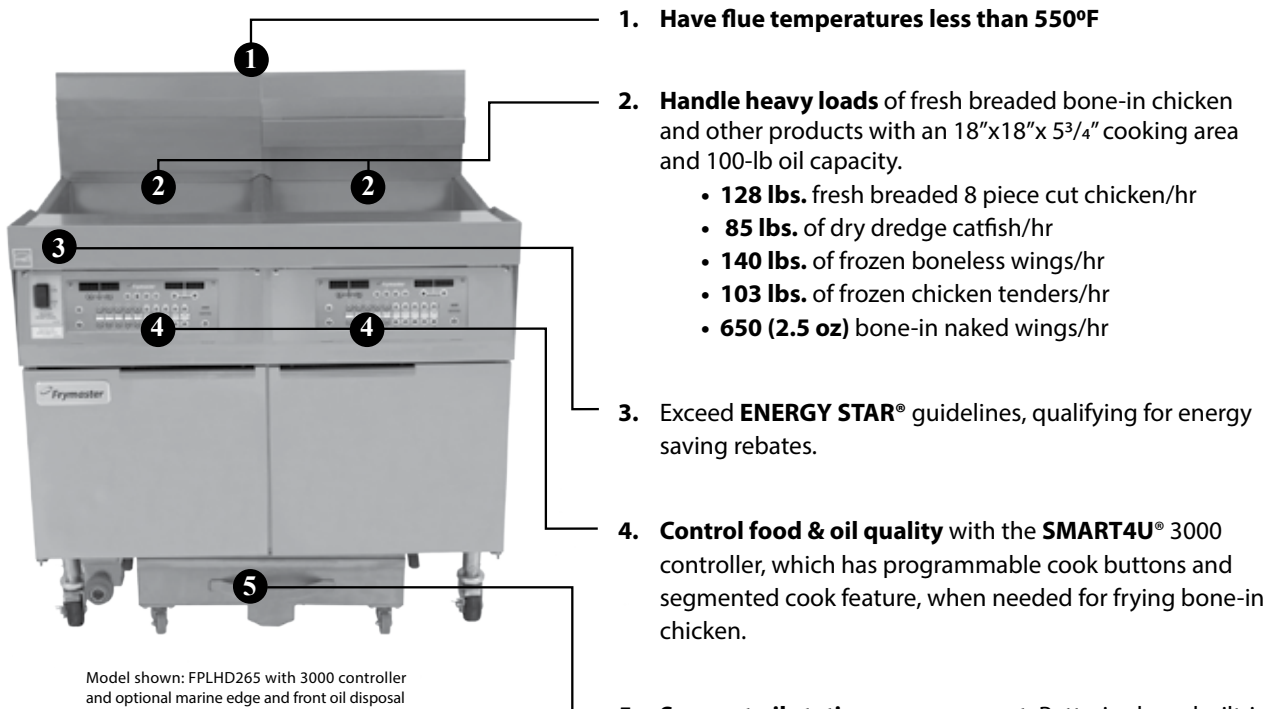

6. Optimize heat transfer with 6" vs. 4" diameter tubes, which provide a 36% larger surface for oil contact and reduce the heat load/sq inch 22% so oil lasts longer.

7. Handle high-sediment foods with ease. Large sloping bottom ensures fast drainage and easy cleaning.



LHD65 fryers meet ENERGY STAR® guidelines and are part of the Manitowoc EnerLogic® energy program.

LOW FLUE TEMPERATURE GAS FRYERS

LHD65 FRYERS WITHOUT FILTRATION, WITH STAINLESS STEEL FRYPOT, DOOR AND CABINET SIDES						
MODEL NUMBER	THERMATRON CONTROLLER	SMART4U 3000 CONTROLLER*	OIL CAPACITY LBS.	COOK AREA W" x L" x D"	BTU/HR INPUT	SHIPPING WEIGHT LBS
LHD165	\$10,799	\$13,299	100 lbs	18 x 18 x 5-3/4	105,000	260

LHD65 FRYER BATTERIES WITH FILTRATION, STAINLESS STEEL FRYPOTS, DOORS AND CABINET SIDES						
MODEL NUMBER	THERMATRON CONTROLLER	SMART4U 3000 CONTROLLER*	OIL CAPACITY LBS.	COOK AREA W" x L" x D"	BTU/HR INPUT	SHIPPING WEIGHT LBS
FPLHD265	\$38,649	\$42,749	(2) 100 lbs	(2) 18 x 18 x 5-3/4	(2) 105,000	750
FPLHD365	\$48,999	\$55,399	(3) 100 lbs	(3) 18 x 18 x 5-3/4	(3) 105,000	1,100
FPLHD465	\$59,399	\$68,099	(4) 100 lbs	(4) 18 x 18 x 5-3/4	(4) 105,000	1,400
FPLHD565	\$69,749	\$80,749	(5) 100 lbs	(5) 18 x 18 x 5-3/4	(5) 105,000	750/1,100 (2) crates
FPLHD665	\$80,099	\$93,399	(6) 100 lbs	(6) 18 x 18 x 5-3/4	(6) 105,000	750/1,400 (2) crates

*Standard with SMART4U 3000 controller.

NOTES:

- Filter price included.
- Price includes casters.

STANDARD ACCESSORIES	
3000 Controller Electronic Ignition 11" Plate Shelf with Marine Edge Basket Hangers	Filter models have: Casters Filter Starter Kit 8 GPM Pump Drain Safety Switch

FRYER ACCESSORIES			
Basket, dual size Part No. 8030304	\$169	Flue Deflector Part No. 8235801	\$113
Basket, triplet size Part No. 8030427	\$183	L- Basket Support Rack Part No. 8103066	\$201
Basket, full size Part No. 8030148	\$259	One-piece manifold with tee (located behind second frypot from left for FPLHD565 only)	CALL CUSTOMER SERVICE AT 1-800-221-4583.
Basket Hanger Part No. 8235859	\$107	Quick Disconnect Hose 1" gas line, 36" long Part No. 8061698	\$604
Basket Support Rack Part No. 8102235	\$167	Quick Disconnect Hose 1" gas line, 48" long Part No. 8061699	\$648
Basket Support Rack, fine mesh Part No. 8030149	\$159	Quick Disconnect Hose 3/4" gas line, 36" long Part No. 8061701	\$491
Brush, L-shaped Tampico 21" L x 2" Diameter Part No. 8030429	\$65	Quick Disconnect Hose - 3/4" gas line, 48" long Part No. 8061700	\$535
Brush, L-shaped Teflon 26-3/4" L x 1" Diameter Part No. 8030278	\$78	Sediment Tray Part No. 1062631	\$535
CASTERS - set of four	\$284	Splash Shield Part No. 8235789	\$189
Frypot cover Part No. 1062897	\$308		

NOTES:

- If elevation is between 2,000 - 6,000 feet, specify the elevation level. Fryer may not perform at optimum levels above this elevation.
- Any questions or pricing information other than the above should be referred to **CUSTOMER SERVICE -- TOLL FREE 1-800-221-4583.**

EXTERNAL OIL DISCHARGE OPTIONS	
External oil discharge - available on built-in filter batteries of 2 or more frypots. Must specify front or rear connection. Front connection comes with 5' washdown hose	Front \$1,593 Rear \$1,082

FILTERING ACCESSORIES			
Filter Powder (80, 1oz. Packs) Part No. 8030002	\$100	Sediment Scoop Part No. 8233696	\$50
Filter Screen (high sediment) 10-3/4 x 14 Part No. 8239068 Set of 2 required	\$299/each	80/100 Series Fryer, 100 UFF** Filter Paper 26 x 34 Box of 100 sheets Part No. 8030303	\$217
Gloves, black safety Part No. 8030293	\$50		

RECOMMENDED STANDARD ACCESSORY PACKAGES	
Standard Frying: Basket support rack(s) (8102235) Basket hanger with flue deflector(s) (8235859) Dual size baskets (8030304)	Bone-in Chicken: L-Basket support rack(s) (8103066) Flue deflector(s) (8235801) Full size basket(s) (8030148)
Recommended Standard Accessories can be ordered per frypot. Example: FPLHD265 -- one standard frying package and one bone-in chicken package.	

GAS MANIFOLD REQUIREMENTS		
1" rear gas manifold (per fryer)	WITH FILTER: with shut-off valve	\$82
	without shut-off valve	Standard

FRYMASTER GAS LINE TABLE		
# OF FRYERS	GAS LINE WITHOUT FILTER	GAS LINE WITH FILTER
1	3/4"	3/4"
2-4	N/A	(1) 1"
5-6	N/A	(2) 1"



High-Efficiency (HD) Gas Fryers

“Tube Fryers Good Enough to be Frymaster”



1. Are designed for high-volume frying and maximum efficiency. Rapid, yet controlled heat-up, low idle cost, and low gas consumption per pound of food cooked make the HD gas fryers the MVPs of high-efficiency, tube-type frying.

2. Meet a wide range of high-production needs with models offering from 50 to 80-lb. oil capacities, 3-1/2" to 3-3/4" cooking depths, 100,000 to 125,000 Btu/hr inputs, and 14" x 14" x 3-3/4" to 18" x 18" x 5-3/4" frying areas.

3. Handle a wide range of menu items. HD fryers are ideal for everything from fries to bone-in chicken to other breaded foods, and large-size menu items requiring more frying area.

4. Offer easy-to-operate, quick, convenient and reliable filtration option that maintains food quality, extends the useful cooking life of oil, and saves money.

HD260 fryer shown with optional CM3.5* controller and built-in filtration.

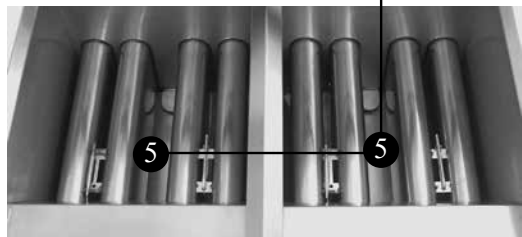

5. Make short work of high-sediment frying. The wide cold zone traps sediment away from the cooking area, safeguarding the quality of the oil and the foods being cooked. Sloping bottom ensures fast draining and easy cleaning.

6. Control food quality with the ThermoTron®* controller's quick response to temperature changes and precise control of cooking temperatures. The optional controllers (CM3.5* and SMART4U® 3000) add cooking compensation and count down timers for an elite level of control.

7. Provide energy efficiency that translates to savings. New Thermo-Tube design provides an additional 2" of tube height and 36% more heat transfer surface area. This reduces the heat/sq inch on the oil by 22%, for more efficient heat transfer and longer lasting oil life.

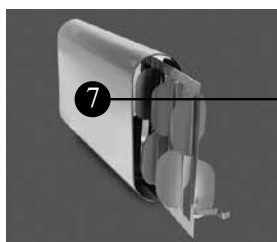
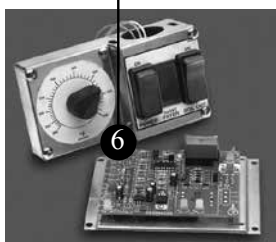

HD Fryers maintain high-production cooking capacity and fast recovery to meet peak demands, while realizing energy savings.

*Not available for CE.

For more information, contact customer service at 1-800-221-4583 or visit www.frymaster.com.



HD50 fryers meet ENERGY STAR® guidelines. All HD fryers are part of the Manitowoc EnerLogic® energy program.

HIGH EFFICIENCY DECATHLON (HD) GAS FRYERS

HD FRYERS WITHOUT FILTRATION, WITH STAINLESS STEEL FRYPOT, DOOR AND CABINET SIDES							
MODEL NUMBER	THERMATRON CONTROLLER*	CM 3.5 CONTROLLER	SMART4U 3000 CONTROLLER	OIL CAPACITY LBS	COOK AREA W" x L" x D"	BTU/HR INPUT	SHIPPING WEIGHT LBS
HD150G	\$8,349	\$10,149	\$10,849	50	14 x 14 x 3-1/2	100,000	180
HD160G	\$9,599	\$11,399	\$12,099	80	18 x 18 x 3-3/4	125,000	255

*Standard with Thermatron controller.

HD50 FRYERS WITH FILTRATION, STAINLESS STEEL FRYPOT(S), DOOR(S) AND CABINET SIDES							
MODEL NUMBER	THERMATRON CONTROLLER*	CM 3.5 CONTROLLER	SMART4U 3000 CONTROLLER	OIL CAPACITY LBS	COOK AREA W" x L" x D"	BTU/HR INPUT/ FRYPOT	SHIPPING WEIGHT LBS
CFHD150G	\$18,750	\$19,950	\$20,650	(1) 50	14 x 14 x 3-1/2	100,000	354
SCFHD250G	\$27,899	\$31,499	\$32,899	(2) 50	(2) 14 x 14 x 3-1/2	(2) 100,000	677
SCFHD350G	\$37,099	\$43,099	\$45,199	(3) 50	(3) 14 x 14 x 3-1/2	(3) 100,000	1,083
SCFHD450G	\$46,249	\$54,649	\$57,449	(4) 50	(4) 14 x 14 x 3-1/2	(4) 100,000	1,403
SCFHD550G	\$55,399	\$66,199	\$69,699	(5) 50	(5) 14 x 14 x 3-1/2	(5) 100,000	1,740
SCFHD650G	\$64,599	\$77,799	\$81,999	(6) 50	(6) 14 x 14 x 3-1/2	(6) 100,000	2,094

*Standard with Thermatron controller.

NOTES:

- Filter price included.
- Filter price includes casters.
- Add \$2,500/frypot for basket lifts (not available with Thermatron controller.)
- 4 GPM pump standard.

HD60 FRYER BATTERIES WITH FILTRATION, STAINLESS STEEL FRYPOT(S), DOOR AND CABINET SIDES							
MODEL NUMBER	THERMATRON CONTROLLER	CM 3.5 CONTROLLER	SMART4U 3000 CONTROLLER	OIL CAPACITY LBS/FRYPOT	COOK AREA W" x L" x D"	BTU/HR INPUT/ FRYPOT	SHIPPING WEIGHT LBS
CFHD160G	\$21,099	\$22,899	\$23,599	(1) 80	(1) 18 x 18 x 3-3/4	(1) 125,000	354
SCFHD260G	\$31,599	\$35,199	\$36,599	(2) 80	(2) 18 x 18 x 3-3/4	(2) 125,000	677
SCFHD360G	\$42,149	\$48,149	\$50,249	(3) 80	(3) 18 x 18 x 3-3/4	(3) 125,000	1,083
SCFHD460G	\$52,649	\$61,049	\$63,849	(4) 80	(4) 18 x 18 x 3-3/4	(4) 125,000	1,403
SCFHD560G	\$63,149	\$73,949	\$77,449	(5) 80	(5) 18 x 18 x 3-3/4	(5) 125,000	1,740
SCFHD660G	\$73,649	\$86,849	\$91,049	(6) 80	(6) 18 x 18 x 3-3/4	(6) 125,000	2,094

*Thermatron controller standard.

NOTES:

- Filter price included.
- Filter price includes casters.
- Add \$2,500/frypot for basket lifts (not available with Thermatron controller.)
- 8 GPM pump standard.

FILTERING ACCESSORIES			
8GPM Filter Pump Upgrade HD50 (models only)	\$437	Filter Powder (80, 1oz. Packs) Part No. 8030002	\$100
Gloves, black safety Part No. 8030293	\$50	60 Fryer, SUFF* equipped, 33-1/4 x 17, Box of 100 sheets Part No. 8030345	\$217
Sediment Scoop Part No. 8233696	\$50	50/60 Fryer, UFF** Filter Paper; 22 x 34 Box of 100 sheets Part No. 8030289	\$217
Filter Screen (high sediment) 10-3/4 x 14 Part No. 8239068 Set of 2 required	\$299/each		

* SUFF-Equipped systems are single frypots with built-in filtration only.

** UFF-Equipped systems are multi-battered frypots with built-in filtration only.

EXTERNAL OIL DISCHARGE	
External oil discharge -- available on built-in filter batteries of two or more frypots or a frypot spreader -- must specify front or rear connection. Front connection comes with 5ft. washdown hose.	Front \$1,593 Rear \$1,082

SPREADERS - ADD TO PRICE OF FRYER(S)	
HD50G -- 15MC	\$999
HD60G -- 20MC	\$1,299

NOTE:

- Call Customer Service for availability and placement.

STANDARD ACCESSORIES	
Electronic Ignition Automatic Melt Cycle Boil-out Temperature Control Legs (non-filter models)	Rack-type Basket Support Basket Hanger Twin Baskets Drain Safety Switch Casters (filter models)

NOTES:

- If elevation is between 2,000 - 6,000 feet, specify the elevation level. Fryer may not perform at optimum levels above this elevation.
- Any questions or pricing information other than the above should be referred to **CUSTOMER SERVICE -- TOLL FREE 1-800-221-4583.**

HIGH EFFICIENCY DECATHLON (HD) GAS FRYERS (CONTINUED)

GAS MANIFOLD REQUIREMENTS		
1" rear gas manifold (per fryer)	WITH FILTER: with shut-off valve	\$82
	without shut-off valve	Standard

FRYMASTER GAS LINE TABLE		
# OF FRYERS	GAS LINE WITHOUT FILTER	GAS LINE WITH FILTER
	Singles	
1	3/4"	3/4"
2 - 4	N/A	(1) 1"
5 - 6	N/A	(2) 1"

FRYER ACCESSORIES				
Basket, full size - HD50G 12-3/8 x 12-7/8 x 5-1/4 Part No. 8030099	\$244	Cover, frypot with basket lift - HD50G Part No. 1062734	\$239	
Basket, full size - HD60G 17-1/2 x 16-3/4 x 6 Part No. 8030017	\$259	Cover, frypot with basket lift - HD60G Part No. 1062773	\$304	
Basket, triplet size - HD50G 4-1/2 x 13-1/4 x 6 Part No. 8030357	\$159	Fish Scoop 8-1/8 W x 8-1/2 D w/ 17-3/8 handle Part No. 8030059	\$96	
Basket, triplet size - HD60G 5-5/8 x 15-7/8 x 7-1/4 Part No. 8030427	\$183	Fish Skimmer 6" square w/ insulated handle Part No. 8030184	\$87	
Basket, twin size - HD50G 5-7/8 x 12-5/8 x 6-5/8 Part No. 8030271	\$163	Foam Deck Basket Banger - HD50G, HD60G	\$190/frypot	
Basket, twin size - HD60G 8-3/4 X 16-3/4 x 5-1/4 Part No. 8030304	\$169	Legs - 6" H, set of four (non-filter models only)	\$284	
Basket, chicken - HD60G 16-7/8 x 17 x 7-1/2 Part No. 8102384	\$489	Quick Disconnect Hose 1" gas line, 36" long Part No. 8061698	\$604	
Basket Hanger - HD50G (single model) Part No. 2101595	\$91 (Call Customer Service for battered models)	Quick Disconnect Hose 1" gas line, 48" long Part No. 8061699	\$648	
Basket Hanger - HD60G (single model) Part No. 2102737	\$91 (Call Customer Service for battered models)	Quick Disconnect Hose 3/4" gas line, 36" long Part No. 8061701	\$491	
Basket Support Rack - HD50G 13-1/2 W x 13-1/4 D Part No. 8030273	\$91	Quick Disconnect Hose - 3/4" gas line, 48" long Part No. 8061700	\$535	
Basket Support Rack - HD60G Part No. 8102235	\$167	Sediment Tray - HD50G 13-1/2 W x 13-3/4 D Part No. 1064136	\$453	
Basket Support Rack, fine mesh - HD50G Part No. 8030277	\$87	Sediment Tray - HD60G 17-1/4 W x 17-3/4 D Part No. 1062631	\$535	
Basket Support Rack, fine mesh - HD60G Part No. 8030149	\$159	Shelf, Front Work 10" without marine edge- must be requested with fryer order HD150G, HD250G, HD350G, HD450G, HD550G, HD160G, HD260G, HD360G, HD460G, HD560G	\$602 per frypot	
Brush, L-shaped Tampico 21" L x 2" Diameter Part No. 8030429	\$65	Shelf, Front Work 6" with marine edge- must be requested with fryer order HD160G, HD260G	\$702 per frypot	
Brush, L-shaped Teflon 26-3/4" L x 1" Diameter Part No. 8030278	\$78	Splash Shield - HD50G Part No. 8233225	\$111	
CASTERS - set of four	\$284	Splash Shield - HD60G Part No. 8235744	\$129	
Chicken/Fish Tray--HD50G Part No. 2208963	\$337	Top Connecting Strip - HD50G Part No. 2102681	\$139	
Chicken/Fish Tray--HD60G 16-1/2 x 16-1/2 x 11 Part No. 8233947	\$351	Top Connecting Strip - HD60G Part No. 2105086	\$163	
Clean-out rod 27" long Part No. 8030197	\$83	8 GPM Pump Option - HD50	\$437	
Cover, frypot w/o basket lift - HD50G 13-1/2 W x 21-3/8 D Part No. 1061637	\$239			
Cover, frypot w/o basket lift - HD60G Part No. 1061479	\$304			



H55 Gas Fryers

Set the Standard for High-Efficiency, Open-Pot Frying

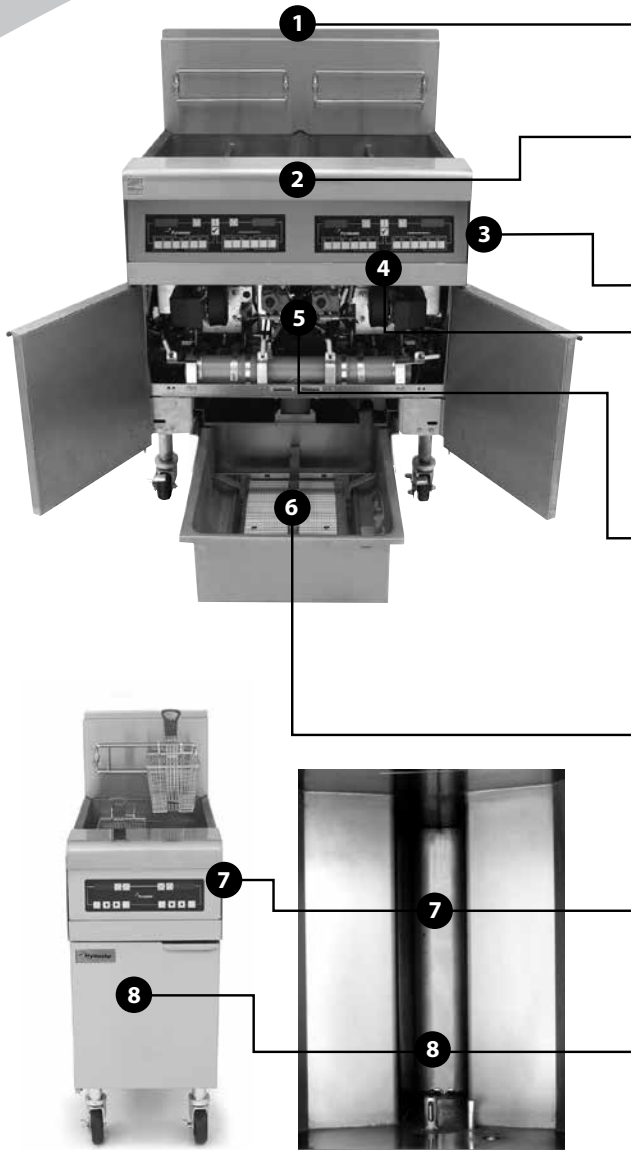

1. **Combine state-of-the-art combustion technology with decades of frying experience** to set a world standard for high-efficiency frying.
2. **Are the industry's first GREEN fryers**, meeting ENERGY STAR® standards long before any standards were established. H55 fryers are the foundation of Frymaster's ever evolving conserving fryer technology.
3. **Qualify for energy-saving rebates.**
4. **Ensure consistent, great-tasting food.** RTD, center-mounted temperature probe and digital controller deliver precise heat responses, safeguarding oil life and producing a uniformly-cooked product. Controller (CM3.5 and SMART4U® 3000) and basket lift options provide additional cooking control. The CM3.5 and 3000 controller options offer cooking compensation.
5. **Have a renowned infrared burner and blower system** that delivers an ultra-refined air-gas mixture so the fryer operates well in any gas application.
 - High altitudes
 - Sub-optimal air circulation environments
 - When gas heating quality is diminished
6. **Offer easy-to-operate, quick, convenient and reliable filtration options** that maintain food quality, extend the useful cooking life of oil, and save money. Built-in filtration supports a regular program of filtration proven to dramatically extend oil life, saving thousands of dollars annually on oil costs.
7. **Offer standard features that add convenience and ease of use.**
 - Open frypot is easy to clean
 - Electronic ignition (no pilot to light), melt cycle mode, and boil-out mode.
8. **Protect purchases with an unmatched 7-Year Warranty** that covers the entire combustion chamber (frypot, infrared burners, and combustion components).



H55 fryers meet ENERGY STAR® guidelines for high efficiency. All H55 fryers are part of the Manitowoc EnerLogic® energy program.

H55 fryers have been tested by time and are trusted by operators worldwide.



H55 Exclusive 7-Year Warranty

Protects Your H55 Purchase



Frymaster's #1 selling fryer has a 7-Year Warranty that is unmatched in the industry.

The 7-Year Warranty covers the entire combustion chamber.

Frymaster's exclusive warranty protects your H55 purchase investment by:

- **Covering the Parts and Labor costs** on the combustion chamber for 7 years (frypot, infrared burners and combustion components).
- **Offering this enhanced protection at NO ADDITIONAL COST!**
- **Lowering your overall maintenance and repair costs.**

HIGH EFFICIENCY H55 GAS FRYERS

H55 FRYER WITHOUT FILTRATION, WITH STAINLESS STEEL FRYPOT, DOOR AND CABINET							
MODEL NUMBER	DIGITAL CONTROLLER	CM 3.5 CONTROLLER	SMART4U 3000 CONTROLLER	OIL CAPACITY LBS	COOK AREA W" x L" x D"	BTU/HR INPUT	SHIPPING WEIGHT LBS
PH155 FULL POT	\$10,199	\$11,399	\$12,099	50	14 x 15 x 4-1/2	80,000	202

*Standard with Digital controller.

H55 FRYER BATTERIES WITH FILTRATION, STAINLESS STEEL FRYPOTS, DOORS AND CABINET							
MODEL NUMBER	DIGITAL CONTROLLER	CM 3.5 CONTROLLER	SMART4U 3000 CONTROLLER	OIL CAPACITY LBS	COOK AREA W" x L" x D"	BTU/HR INPUT/FRYPOT	SHIPPING WEIGHT LBS
FPH155 FULL POT	\$20,399	\$21,599	\$22,299	(1) 50	(1) 14 x 15 x 4-1/2	(1) 80,000	306
FPPH255 FULL POT	\$31,499	\$33,899	\$35,299	(2) 50	(2) 14 x 15 x 4-1/2	(2) 80,000	492
FPPH355 FULL POT	\$42,649	\$46,249	\$48,349	(3) 50	(3) 14 x 15 x 4-1/2	(3) 80,000	671
FPPH455 FULL POT	\$53,749	\$58,549	\$61,349	(4) 50	(4) 14 x 15 x 4-1/2	(4) 80,000	881
FPPH555 FULL POT	\$64,899	\$70,899	\$74,399	(5) 50	(5) 14 x 15 x 4-1/2	(5) 80,000	1,076
FPPH655 FULL POT	\$75,999	\$83,199	\$87,399	(6) 50	(6) 14 x 15 x 4-1/2	(6) 80,000	1,236

*Standard with Digital controller.

NOTES:

- Filter price included.
- Price includes casters.
- Add \$1,500 for each split frypot
- Add \$2,500/frypot for basket lifts (not available with digital controller).
- Standard supplies for all filter systems consist of sample packages of filter powder and paper, one filter brush and one clean-out rod.
- Tandem basket lifts - Add \$80 each frypot (full or split).

STANDARD ACCESSORIES	
Electronic Ignition Automatic Melt Cycle Boil-out Temperature Control Legs (non-filter models)	Rack-type Basket Support Basket Hanger Twin Baskets Casters (filter models only)

HIGH EFFICIENCY H55 GAS FRYERS

FRYER ACCESSORIES			
Basket, full size 12-3/8 x 12-7/8 x 5-1/4 Part No. 8030099 <small>(can't be used w/ basket lifts)</small>	\$244	Crumb Scoop - full pot 1-3/4 W x 6-1/2 D x 22-3/4 Long Part No. 8233660	\$89
Basket, triplet size 4-1/2 x 13-1/4 x 6 Part No. 8030357	\$159	Crumb Scoop - split pot 1-1/4 W x 6-1/2 D x 22-3/4 Long Part No. 8233938	\$89
Basket, twin size 5-7/8 x 12-5/8 x 6-5/8 Part No. 8030271	\$163	Fish Scoop 8-1/8 W x 8-1/2 D w/ 17-3/8 handle Part No. 8030059	\$96
Basket Hanger 12-1/2 W x 3-1/2 H Part No. 8102793	\$98	Fish Skimmer 6" square w/ insulated handle Part No. 8030184	\$87
Basket Support Rack - full pot 12-1/2 W x 13-3/4 D Part No. 8030132	\$93	Flue Deflector 12-1/2 W x 6 H Part No. 9103557	\$100
Basket Support Rack - split pot 5-7/8 W x 14 D Part No. 8030133	\$83	Foam Deck Basket Banger*	\$190/frypot
Basket Support Screen - full Pot 12-1/2 W x 13-3/4 D Part No. 8030136	\$129	Legs - 8-1/2" H, set of four (non-filter models only)	\$284
Brush, L-shaped Tampico 21" L x 2" Diameter Part No. 8030429	\$65	Quick Disconnect Hose 1" gas line, 36" long Part No. 8061698	\$604
CASTERS - set of four	\$284	Quick Disconnect Hose 1" gas line, 48" long Part No. 8061699	\$648
Chicken/Fish Tray - full pot 11-3/4 W x 13-1/2 D Part No. 8230619 <small>(Not available for split pot)</small>	\$344	Quick Disconnect Hose 3/4" gas line, 36" long Part No. 8061701	\$491
Clean-out Rod 27" long Part No. 8030197	\$83	Quick Disconnect Hose 3/4" gas line, 48" long Part No. 8061700	\$535
Cover, stainless steel - full pot 15-1/4 W x 20-1/4 D Part No. 8065518	\$220	Sediment Tray - full pot 12-1/2 x 14-1/8 x 6-1/2 Part No. 8030103	\$441
Cover, stainless steel - full pot, Basket Lifts 15 W x 21-1/2 D Part No. 8063068	\$224	Sediment Tray - split pot 5-3/4 x 14 x 6-1/2 Part No. (L) 8030107 Part No. (R) 8030108	\$337
Cover, stainless steel - Split pot 7-1/2 W x 20-3/8 D (2) Part No. 8063232	\$131	Splash Shield 20 D x 6-1/4 H Part No. 8236559	\$113
		Top Connecting Strip Part No. 2109291	\$139

*If ordered after purchase, requires changing top connecting strips.

SPREADERS - ADD TO PRICE OF FRYERS	
SPREADER CABINET Call Customer Service for availability and placement.	\$999

FILTERING ACCESSORIES	
Filter Powder (80, 1oz. Packs) Part No. 8030002	\$100
Filter Paper (19-1/2 x 27-1/2) Box of 100 sheets Part No. 8030170	\$119
Metal Filter Screen * (for built-in filtration) (11-1/8 x 19-1/4) Part No. 8102800	\$682

* Must be requested at time of fryer order.

FRYMASTER GAS LINE INFORMATION
Fryers must be installed with proper size gas line. Each single unit requires a 3/4" NPT connection; battered units (2-3) require one 1" NPT connection; battered units (4-6) require two 1" NPT connections.

EXTERNAL OIL DISCHARGE	
External oil discharge -- available on built-in filter batteries of two or more frypots or a frypot spreader -- must specify front or rear connection. Front connection comes with 5ft. washdown hose.	Front \$1,593 Rear \$1,082

NOTES:

- **CALL CUSTOMER SERVICE -- TOLL FREE 1-800-221-4583** or refer to manual provided with fryer for correct sizing information including high elevation installations.
- If elevation is between 5,000 - 10,000 feet, specify the elevation level. Fryer may not perform at optimum levels above this elevation.
- **DO NOT CURB MOUNT.**
- Any questions or pricing information other than the above should be referred to **CUSTOMER SERVICE -- TOLL FREE 1-800-221-4583.**



MJ Fryers (MJ35, MJ45 and MJCF)

World-Recognized Masters of Open-Pot Frying



MJ35 fryer shown with optional digital controller and casters



*MJ45E battery shown with optional CM 3.5 controller, built-in filtration, and casters



MJCF fryer with optional digital controller and casters

- 1. Offer an open-pot gas line-up unmatched in the industry.** Model offerings provide 40, 50, and 80-lb. oil capacity options with and without electrical hook-up. Respective fry areas are 12" x 15", 14" x 15", and 18" x 19". Respective Btu/hr inputs are 110,000, 122,000, and 150,000.
- 2. Have models that can handle the breadth of menu items** from French fries to breaded fish to bone-in chicken.
- 3. Are named for their signature Master Jet burner** technology that has earned a legendary reputation for durability and reliability. MJ burners require no burner cleaning or air shutter adjustment.
- 4. Are easy to clean.** Open-pot design allows safe access to every inch of the frypot.
- 5. Are simple to operate.** Just set the desired frying temperature and start cooking. A Piezo ignitor option allows simple push button ignition.
- 6. Offer options to meet a variety of operation and food quality control needs:***
 - Built-in filtration, electronic ignition, multiple frypot batteries and controller options including CM3.5 compensating controller. Basket lifts are also available on the MJ45.
- 7. Automatically shut off the fryer** if temperature exceeds the high-limit.
- 8. Collect and aid sediment removal** with a deep collection zone and large 1-1/4" IPS ball-type drain valve

MJ Fryers are unsurpassed in their versatility, proven worldwide performance, and low maintenance needs.

For more information, contact Customer Service at 1-800-221-4583 or visit www.frymaster.com

PERFORMANCE MJ35 GAS FRYERS

MJ35 FRYER WITHOUT FILTRATION, WITH STAINLESS STEEL FRYPOT, DOOR AND CABINET						
MODEL NUMBER	MILLIVOLT CONTROLLER*	DIGITAL CONTROLLER	OIL CAPACITY LBS	COOK AREA W" x L" x D"	BTU/HR INPUT	SHIPPING WEIGHT LBS
PMJ135 FULL POT	\$6,199	\$7,399	40	12 x 15 x 4-1/4	110,000	177

*Standard with Millivolt controller.

MJ35 FRYER BATTERIES WITH FILTRATION, STAINLESS STEEL FRYPOTS, DOORS AND CABINET							
MODEL NUMBER	MILLIVOLT CONTROLLER*	DIGITAL CONTROLLER	CM3.5 CONTROLLER	OIL CAPACITY LBS	COOK AREA W" x L" x D"	BTU/HR INPUT	SHIPPING WEIGHT LBS
FPP235 FULL POT	\$23,499	\$25,899	\$28,299	(2) 40	(2) 12 x 15 x 4-1/4	(2) 110,000	525
FPP335 FULL POT	\$31,199	\$34,799	\$38,399	(3) 40	(3) 12 x 15 x 4-1/4	(3) 110,000	658
FPP435 FULL POT	\$38,949	\$43,749	\$48,549	(4) 40	(4) 12 x 15 x 4-1/4	(4) 110,000	896

*Standard with Millivolt controller.

NOTES:

- Filter price included.
- Price includes casters.

NOTES:

- Piezo Ignitor kit (on millivolt fryers only) - Add \$109/frypot.
- Electronic ignition available with either CM3.5 or Digital controllers - Add \$904.
- Filter located under left two cabinets only.
- Standard supplies for all built-in filter systems consist of sample packages of filter powder and paper, one filter brush and one clean-out rod, or
- Split pots not available.

FRYER ACCESSORIES			
Basket, full size 11-5/8 x 14 x 4-5/8 Part No. 8030015	\$244	Fish scoop 8-1/8 W x 8-1/2 D w/ 17-3/8 handle Part No. 8030059	\$96
Basket, twin size 5-7/8 x 12-5/8 x 6-5/8 Part No. 8030271	\$163	Fish skimmer 6" square w/ insulated handle Part No. 8030184	\$87
Basket Hanger 12-1/2 W x 3-1/2 H Part No. 8102793	\$98	Flue deflector Part No. 9103557	\$100
Basket Hanger, flue mounted Part No. 2105777	\$78	Legs - 6" H, set of four, adjustable nickel Part No. 8103169	\$213
Basket Support Rack - Full pot 11-1/2 W x 14-5/8 D Part No. 8030032	\$87	Legs - 6" H, set of four, adjustable stainless steel Part No. 8101205	\$284
Basket Support Screen - Full Pot 11-1/2 W x 14-5/8 D Part No. 8030037	\$115	Quick Disconnect Hose 1" gas line, 36" long Part No. 8061698	\$604
Brush, L-shaped Tampico 21" L x 2" Diameter Part No. 8030429	\$65	Quick Disconnect Hose 1" gas line, 48" long Part No. 8061699	\$648
CASTERS - set of four Call Customer Service to specify model	\$284	Quick Disconnect Hose 3/4" gas line, 36" long Part No. 8061701	\$491
Chicken/Fish Plate - Full pot 11 W x 14 H Part No. 8233048	\$300	Quick Disconnect Hose 3/4" gas line, 48" long Part No. 8061700	\$535
Clean-out Rod 27" long Part No. 8030197	\$83	Sediment tray - Full pot 11-1/8 x 14-1/2 x 3-3/8 Part No. 8030188	\$363
Cover, stainless steel - Full pot 15 W x 21-1/2 D Part No. 8065518	\$220	Splash Shield 20 D x 6-1/4 H Part No. 8236559	\$113
Crumb Scoop - Full pot 1-3/4 W x 6-1/2 D x 22-3/4 long Part No. 8233660	\$89	Thermostat knob guard Part No. 9100557	\$72
		Top Connecting Strip Part No. 2109291	\$139

NOTES:

- CALL CUSTOMER SERVICE -- TOLL FREE 1-800-221-4583 or refer to manual provided with fryer for correct sizing information including high elevation installations.
- If elevation is between 2,000 - 6,000 feet, specify the elevation level. Fryer may not perform at optimum levels above this elevation.
- Consider piezo ignitor or electronic ignition when using energy-saving hoods.
- **DO NOT CURB MOUNT.**
- Any questions or pricing information other than the above should be referred to **CUSTOMER SERVICE -- TOLL FREE 1-800-221-4583.**

STANDARD ACCESSORIES

Legs (non-filter models) Rack-type Basket Support Basket Hanger	Flue Deflector Twin Baskets Casters (filter models)
---	---

EXTERNAL OIL DISCHARGE

External oil discharge -- available on built-in filter batteries of two or more frypots or a frypot spreader -- must specify front or rear connection. Front connection comes with 5ft. washdown hose.	Front \$1,593 Rear \$1,082
--	-------------------------------

FILTERING ACCESSORIES

Filter Powder (80, 1oz. Packs) Part No. 8030002	\$100
Filter Paper (19-1/2 x 27-1/2) Box of 100 sheets Part No. 8030170	\$119
Metal Filter Screen* (for built-in filtration) (11-1/8 x 19-1/4) Part No. 8102800	\$682

* Must be requested at time of fryer order.

SPREADERS - ADD TO PRICE OF FRYER(S)

SPREADER CABINET Call Customer Service for availability and placement.	\$999
---	-------

FRYMASTER GAS LINE INFORMATION

Fryers must be installed with proper size gas line. Each single unit requires a 3/4" npt connection; battered units (2-3) require one 1" NPT connection; battered units (4-6) require two 1" NPT connections.

PERFORMANCE MJ45 GAS FRYERS

MJ45 FRYER WITHOUT FILTRATION, WITH STAINLESS STEEL FRYPOT, DOOR AND CABINET

MODEL NUMBER	MILLIVOLT CONTROLLER*	DIGITAL CONTROLLER	CM3.5 CONTROLLER	OIL CAPACITY LBS	COOK AREA W" x L" x D"	BTU/HR INPUT	SHIPPING WEIGHT LBS
PMJ145 FULL POT	\$6,999	\$8,199	\$9,399	50	14 x 15 x 5	122,000	202

*Standard with Millivolt controller.

MJ45 FRYER BATTERIES WITH FILTRATION, STAINLESS STEEL FRYPOTS, DOORS AND CABINET

MODEL NUMBER	MILLIVOLT CONTROLLER*	DIGITAL CONTROLLER	CM3.5 CONTROLLER	OIL CAPACITY LBS	COOK AREA W" x L" x D"	BTU/HR INPUT	SHIPPING WEIGHT LBS
FPP245 FULL POT	\$25,349	\$27,749	\$29,149	(2) 50	(2) 14 x 15 x 5	(2) 122,000	525
FPP345 FULL POT	\$33,599	\$37,199	\$39,299	(3) 50	(3) 14 x 15 x 5	(3) 122,000	658
FPP445 FULL POT	\$41,799	\$46,599	\$49,399	(4) 50	(4) 14 x 15 x 5	(4) 122,000	896

*Standard with Millivolt controller.

NOTES:

- Filter price included.
- Price includes casters.

NOTES:

- Add \$2,500 for each split frypot.
- Add \$2,500/frypot for basket lifts (only available with CM3.5 Controller).
- Basket lifts not available with split frypots.
- Piezo Ignitor kit (on millivolt fryers only) - Add \$109 for full frypot; \$209 for each split frypot.
- Electronic ignition is available on full frypot models only with either CM3.5 or Digital controller - Add \$904.
- Filter located under left two cabinets only.
- Standard supplies for all built-in filter systems consist of sample packages of filter powder and paper, one filter brush and one clean-out rod.

FRYER ACCESSORIES

Basket, full size 12-3/8 x 12-7/8 x 5-1/4 Part No. 8030099 <small>(can't be used w/ basket lifts)</small>	\$244	Crumb Scoop - Split pot 1-1/4 W x 6-1/2 D x 22-3/4 Long Part No. 8233938	\$89
Basket, triplet size 4-1/2 x 13-1/4 x 6 Part No. 8030357	\$159	Fish scoop 8-1/8 W x 8-1/2 D w/ 17-3/8 handle Part No. 8030059	\$96
Basket, twin size 5-7/8 x 12-5/8 x 6-5/8 Part No. 8030271	\$163	Fish skimmer 6" square w/ insulated handle Part No. 8030184	\$87
Basket Hanger 12-1/2 W x 3-1/2 H Part No. 8102793	\$98	Flue deflector 12-1/2 W x 6 H Part No. 9103557	\$100
Basket Hanger, flue mounted Part No. 2105777	\$78	Legs - 6" H, set of four, adjustable nickel Part No. 810-3169	\$213
Basket Support Rack - Full pot 12-1/2 W x 13-3/4 D Part No. 8030132	\$93	Legs - 6" H, set of four, adjustable stainless steel Part No. 810-1205	\$284
Basket Support Rack - Split pot 5-7/8 W x 14 D Part No. 8030133	\$83	Quick Disconnect Hose 1" gas line, 36" long Part No. 8061698	\$604
Basket Support Screen - Full Pot 12-1/2 W x 13-3/4 D Part No. 8030136	\$129	Quick Disconnect Hose 1" gas line, 48" long Part No. 8061699	\$648
Brush, L-shaped Tampico 21" L x 2" Diameter Part No. 8030429	\$65	Quick Disconnect Hose 3/4" gas line, 36" long Part No. 8061701	\$491
CASTERS - set of four	\$284	Quick Disconnect Hose 3/4" gas line, 48" long Part No. 8061700	\$535
Chicken/Fish Tray - Full pot 11-3/4 W x 13-1/2 D Part No. 8230619 <small>(Not available for split pot)</small>	\$344	Sediment tray - Full pot 12-1/2 x 14-1/8 x 6-1/2 Part No. 8030103	\$441
Clean-out Rod 27" long Part No. 8030197	\$83	Sediment tray - Split pot 5-3/4 x 14 x 6-1/2 Part No. (L) 8030107 Part No. (R) 8030108	\$337
Cover, stainless steel - Full pot 15 W x 21-1/2 D Part No. 8065518	\$220	Splash Shield 20 D x 6-1/4 H Part No. 8236559	\$113
Cover, stainless steel - Full pot, Basket Lifts 15 W x 21-1/2 D Part No. 8063068	\$224	Thermostat knob guard (controller outside cabinet only) Part No. 9100557	\$72
Cover, stainless steel Split pot 7-1/2 W x 20-3/8 D Part No. 8063232	\$131	Top Connecting Strip Part No. 2109291	\$139
Crumb Scoop - Full pot 1-3/4 W x 6-1/2 D x 22-3/4 long Part No. 8233660	\$89		

STANDARD ACCESSORIES

Legs (non-filter models) Rack-type Basket Support Basket Hanger	Flue Deflector Twin Baskets Casters (filter models)
---	---

EXTERNAL OIL DISCHARGE

External oil discharge -- available on built-in filter batteries of two or more frypots or a frypot spreader -- must specify front or rear connection. Front connection comes with 5ft. washdown hose.	Front \$1,593 Rear \$1,082
--	-------------------------------

FILTERING ACCESSORIES

Filter Powder (80, 1oz. Packs) Part No. 8030002	\$100
Filter Paper (19-1/2 x 27-1/2) Box of 100 sheets Part No. 8030170	\$119
Metal Filter Screen** (for built-in filtration) (11-1/8 x 19-1/4) Part No. 8102800	\$682

** Must be requested at time of fryer order.

SPREADERS - ADD TO PRICE OF FRYER BATTERY

SPREADER CABINET Call Customer Service for availability and placement.	\$999
---	-------

MJ45 SPEC SHEET



FRYMASTER GAS LINE INFORMATION

Fryers must be installed with proper size gas line. Each single unit requires a 3/4" NPT connection; battered units (2-3) require one 1" NPT connection; battered units (4-6) require two 1" NPT connections.

NOTES:

- **CALL CUSTOMER SERVICE -- TOLL FREE 1-800-221-4583** or refer to manual provided with fryer for correct sizing information including high elevation installations.
- If elevation is between 2,000 - 6,000 feet, specify the elevation level. Fryer may not perform at optimum levels above this elevation.
- Consider piezo ignitor or electronic ignition when using energy-saving hoods.
- **DO NOT CURB MOUNT.**
- Any questions or pricing information other than the above should be referred to **CUSTOMER SERVICE -- TOLL FREE 1-800-221-4583.**

PERFORMANCE MJCF GAS FRYERS

MJCF FRYER WITHOUT FILTRATION, WITH STAINLESS STEEL FRYPOT, DOOR AND CABINET

MODEL NUMBER	MILLIVOLT CONTROLLER*	DIGITAL CONTROLLER	OIL CAPACITY LBS	COOK AREA W" x L" x D"	BTU/HR INPUT	SHIPPING WEIGHT LBS
MJ1CF FULL POT	\$8,249	\$9,449	80	18 x 19 x 4-1/2	150,000	297

*Standard with Millivolt controller.

MJCF FRYER BATTERIES WITH FILTRATION, STAINLESS STEEL FRYPOTS, DOORS AND CABINET

MODEL NUMBER	DIGITAL CONTROLLER	CM 3.5 CONTROLLER	SMART4U 3000 CONTROLLER	OIL CAPACITY LBS	COOK AREA W" x L" x D"	BTU/HR INPUT	SHIPPING WEIGHT LBS
SFM1CFE FULL POT	\$20,899	\$22,099	\$22,799	(1) 80	(1) 18 x 19 x 4-1/2	(1) 150,000	440
SFM2CFE FULL POT	\$31,499	\$33,899	\$35,299	(2) 80	(2) 18 x 19 x 4-1/2	(2) 150,000	641
SFM3CFE FULL POT	\$42,099	\$45,699	\$47,799	(3) 80	(3) 18 x 19 x 4-1/2	(3) 150,000	842

NOTES:

- Filter price included.
- Price includes casters.
- Filter price includes the required filter spreader cabinet.
- Filter price includes the required Power Shower for oil return to the frypot.

NOTES:

- MJCF & MJCFE fryers do not have basket lift options.

FRYER ACCESSORIES

Basket, full size 17-1/2 x 16-3/4 x 6 Part No. 8030017	\$259	Fish Skimmer 6" square w/ insulated handle Part No. 8030184	\$87
Basket, triplet size 5-3/4 x 17-1/8 x 6-1/8 Part No. 8030023	\$195	Flue Deflector Part No. 9103185	\$105
Basket, twin size 8-3/4 x 16-3/4 x 6 Part No. 8030024	\$252	Legs - 6"H, set of four, adjustable nickel Part No. 8103169	\$213
Basket Hanger 17-3/8 W x 3-1/2 H Part No. 8102794	\$100	Legs - 6"H, set of four, adjustable stainless steel Part No. 8101205	\$284
Basket Support Rack - full pot Part No. 8030137	\$102	Quick Disconnect Hose 3/4" gas line, 36" long Part No. 8061701	\$491
Basket Support Screen - full pot 17-1/2 W x 18-1/2 D Part No. 8030138	\$135	Quick Disconnect Hose 3/4" gas line, 48" long Part No. 8061700	\$535
Brush, L-shaped Tampico 21" L x 2" Diameter Part No. 8030429	\$65	Quick Disconnect Hose 1" gas line, 36" long Part No. 8061698	\$604
CASTERS - set of four	\$284	Quick Disconnect Hose 1" gas line, 48" long Part No. 8061699	\$648
Chicken/Fish Tray - full pot 17 W x 18 D Part No. 8230368	\$419	Sediment tray - full pot Part No. 8030187	\$465
Clean-out Rod 27" long Part No. 8030197	\$83	Splash Shield 30-3/8 D x 13-1/8 H Part No. 8235978	\$121
Cover, stainless steel - full pot 20-3/8 W x 28 D Part No. 8061343	\$248	Thermostat Knob Guard Part No. 9100557	\$72
Crumb Scoop - full pot 1-3/4 W x 6-1/2 D x 22-3/4 Long Part No. 8233660	\$89	Top Connecting Strip Part No. 9102662	\$163
Fish Scoop 8-1/8 W x 8-1/2 D w/ 17-3/8 handle Part No. 8030059	\$96		

NOTES:

- **CALL CUSTOMER SERVICE -- TOLL FREE 1-800-221-4583** or refer to manual provided with fryer for correct sizing information including high elevation installations.
- If elevation is between 2,000 - 6,000 feet, specify the elevation level. Fryer may not perform at optimum levels above this elevation.
- Consider piezo ignitor or electronic ignition when using energy-saving hoods.
- **DO NOT CURB MOUNT.**
- Any questions or pricing information other than the above should be referred to **CUSTOMER SERVICE -- TOLL FREE 1-800-221-4583.**

STANDARD ACCESSORIES

Legs (non-filter model)
Rack-type Basket Support

Basket Hanger
Twin Baskets
Casters (filter models)

EXTERNAL OIL DISCHARGE

External oil discharge -- available on built-in filter batteries of two or more frypots or a frypot spreader -- must specify front or rear connection. Front connection comes with 5ft. washdown hose.

Front \$1,593
Rear \$1,082

FREE-STANDING OR ADDITIONAL SPREADERS - ADD TO PRICE OF FRYER(S)

SPREADER CABINET
Call Customer Service for availability and placement.

\$1,599

FILTERING ACCESSORIES

Filter Powder
(80, 1oz. Packs)
Part No. 8030002

\$100

Filter Paper (22 x 34)
Box of 100 sheets
Part No. 8030289

\$217

FRYMASTER GAS LINE INFORMATION

Fryers must be installed with proper size gas line. Each single unit requires a 3/4" NPT connection; battered units (2-3) require one 1" NPT connection; battered units (4-6) require two 1" NPT connections.



GF Fryers

Deliver Outstanding Open-Pot Frying Performance

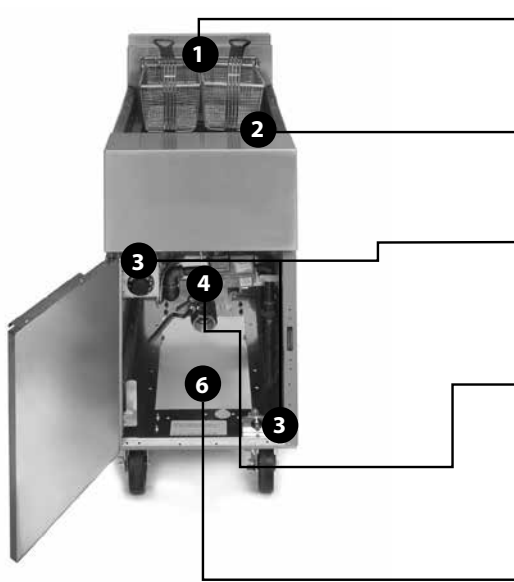

GF14 fryer shown with optional Piezo ignitor

1. **Are designed for versatile frying production.** Model offerings provide 40 and 50-lb. oil capacity options.
2. **Are easy to clean.** Open-pot design allows safe access to every inch of the frypot.
3. **Are simple to operate.** Just set the desired frying temperature and start cooking. A Piezo ignitor option allows simple push button ignition.
4. **Automatically shut off the fryer** if temperature exceeds the high-limit.
5. **Require no electrical hookup.**
6. **Have a durable heat transfer system** that can be counted on for years of reliable performance.

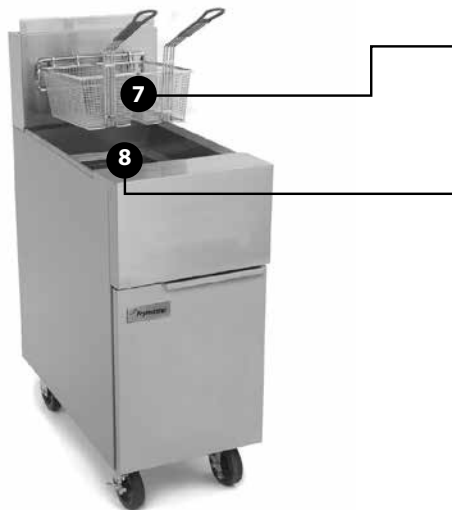

GF40

7. **Have durable accessories that support frying operation** including the Piezo ignitor, frypot covers, full size baskets, basket support screen, and casters.
8. **Collect and aid sediment removal** with a deep collection zone and large 1-1/4" IPS ball-type drain valve.

GF Fryers offer all the benefits of open-pot frying at an entry level price.

STANDARD GF GAS FRYERS - GF SERIES

GF FRYERS WITH STAINLESS STEEL FRYPOT, DOOR AND CABINET					
MODEL NUMBER	MILLIVOLT CONTROLLER	OIL CAPACITY LBS	COOK AREA W" x L" x D"	BTU/HR INPUT	SHIPPING WEIGHT LBS
GF14 FULL POT	\$3,149	40	12 x 15 x 4	100,000	152
GF40 FULL POT	\$4,549	50	14 x 15 x 5	122,000	176

NOTES:

- Piezo Ignitor - Add \$109 per frypot.
- GF14 and GF40 fryers do not have basket lift, built-in filtration, battery options or split pots.

FRYER ACCESSORIES			
Basket, full size, GF 40 5-1/4 x 12-3/8 x 12-7/8 Part No. 8030099	\$244	Clean-out Rod 27" long Part No. 8030197	\$83
Basket, full size, GF14 11-5/8 x 14 x 4-5/8 Part No. 8030015	\$244	Cover, stainless steel 15 W x 21-1/2 D Part No. 8065518	\$220
Basket, triplet size, GF40 4-1/2 x 13-1/4 x 6 Part No. 8030357	\$159	Fish scoop 8-1/8 W x 8-1/2 D w/ 17-3/8 handle Part No. 8030059	\$96
Basket, twin size 5-7/8 x 12-5/8 x 6-5/8 Part No. 8030271	\$163	Fish skimmer 6" square w/ insulated handle Part No. 8030184	\$87
Basket Support Rack GF40 12-1/2 W x 13-3/4 D Part No. 8030132	\$93	Flue deflector GF40 12-1/2 W x 6 H Part No. 9103557	\$100
Basket Support Rack - GF14 11-1/2 W x 14-5/8 D Part No. 8030032	\$87	Flue deflector GF14 Part No. 9103557	\$100
Basket Support Screen - GF40 12-1/2 W x 13-3/4 D Part No. 8030136	\$129	Quick Disconnect Hose 3/4" gas line, 36" long Part No. 8061701	\$491
Basket Support Screen - GF14 11-1/2 W x 14-5/8 D Part No. 8030037	\$115	Quick Disconnect Hose 3/4" gas line, 48" long Part No. 8061700	\$535
Brush, L-shaped Tampico 21" L x 2" Diameter Part No. 8030429	\$65	Sediment tray - GF40 12-1/2 x 14-1/8 x 6-1/2 Part No. 8030103	\$441
Chicken/Fish Plate - GF40 11-3/4 W x 13-1/2 D Part No. 8230619	\$344	Sediment tray - GF14 11-1/8 x 14-1/2 x 3-3/8 Part No. 8030188	\$363
Chicken/Fish Plate - GF14 11 W x 14 D Part No. 8233048	\$300	Top Connecting Strip Part No. GF14 9102285 GF40 9104617	\$139

STANDARD ACCESSORIES	
Full Set Legs and Casters included Rack-type Basket Support Basket Hanger	Flue Deflector Twin Baskets

FRYMASTER GAS LINE INFORMATION
Fryers must be installed with proper size gas line. Each single unit requires a 3/4" NPT connection.

NOTES:

- **CALL CUSTOMER SERVICE -- TOLL FREE 1-800-221-4583** or refer to manual provided with fryer for correct sizing information including high elevation installations.
- If elevation is between 2,000 - 6,000 feet, specify the elevation level. Fryer may not perform at optimum levels above this elevation.
- Consider piezo ignitor when using energy-saving hoods.
- **DO NOT CURB MOUNT.**
- Any questions or pricing information other than the above should be referred to Customer Service -- Toll Free 1-800-221-4583.



FilterQuick® With Automatic Filtration and Optional Oil Quality Sensor Electric Fryers

Fingertip Filtration Plus:
40% Less Oil, 10% Less Energy, Outstanding Results

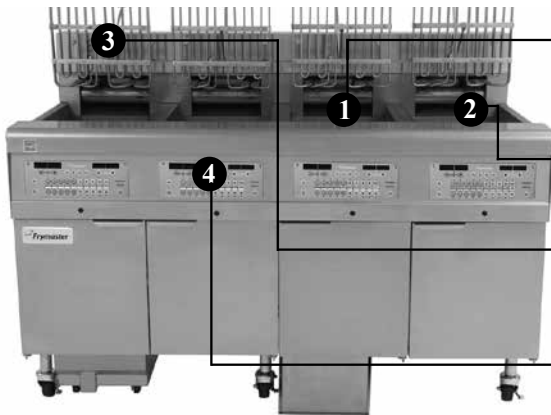

- 1. **30-lb. open frypot design** requires 40% less oil and ensures quick and easy cleaning. Saves money, time and labor.
- 2. **Independent frypot construction** allows convenient frypot repairs in the field, if needed.
- 3. **Safe, self-standing heating elements** ensure industry leading energy efficiency and sealed rotation housing protects against oil migration.
- 4. **SMART 4U® FilterQuick Controller** has operation management features that monitor and help control food and oil quality, oil life, and equipment performance. Has 20 programmable cook buttons and auto adjusts cook time to load size.

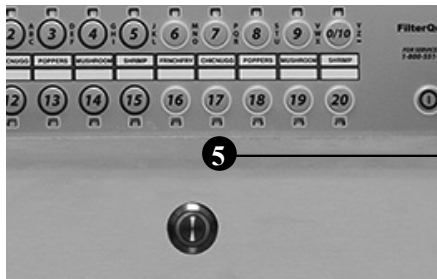

- 5. **Fingertip, closed cabinet, full-automatic filtration** starts with push-button ease. It makes caring for the oil and optimizing food quality simple
 - Safe technology ensures only one frypot can drain at a time. Filtration is as easy as pushing a button.
 - The filter pump agitates the oil in the frypot before draining to lift the crumbs from the bottom of the frypot, aiding their removal.
 - The frypot begins heating as soon as a safe level of oil returns to the frypot to speed return to set temperature.
 - The pump is protected from bulk oil connection dead heading.

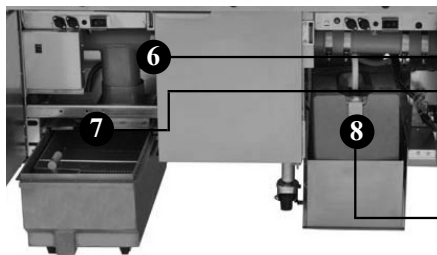

- 6. **Optional oil quality sensor** monitors the oil's health and advises when to discard. No more guesswork.
- 7. **Innovative safety features** offer proprietary advantages over other fryers – prevent simultaneous vat filtrations.
- 8. **Oil Attendant® auto fill feature** senses the oil level and adds oil as needed from an in-cabinet supply.



FilterQuick fryers exceed ENERGY STAR® guidelines for high efficiency and are part of the Manitowoc EnerLogic® program

OIL-CONSERVING FILTERQUICK ELECTRIC FRYERS WITH FULLY-AUTOMATIC FILTRATION

FILTERQUICK FRYER BATTERIES WITH FILTRATION, AUTO TOP-OFF, STAINLESS STEEL FRYPOTS, DOORS AND CABINET

MODEL NUMBER	OIL MANAGEMENT PACKAGE*	OIL CAPACITY LBS	COOK AREA W" x L" x D"	ELECTRICAL INPUT	SHIPPING WEIGHT LBS
2FQE30U FULL POT	\$29,749	(2) 30	(2) 13 x 14 x 3-3/4	14 kw	535
3FQE30U FULL POT	\$40,899	(3) 30	(3) 13 x 14 x 3-3/4	14 kw	667
4FQE30U FULL POT	\$51,999	(4) 30	(4) 13 x 14 x 3-3/4	14 kw	978
5FQE30U FULL POT	\$63,149	(5) 30	(5) 13 x 14 x 3-3/4	14 kw	1,202

*Standard with FilterQuick controller.

NOTES:

- Split frypots - Add \$2,000 for each split frypot.
- Basket Lifts - Add \$2,500 for each frypot (full or split).
- Casters included in pricing.
- Tandem basket lifts - Add \$80 each frypot (full or split).

FRYER ACCESSORIES

Basket, full size 12-3/8 x 12-7/8 x 5-1/4 Part No. 8030099 (can't be used w/ basket lifts)	\$244	Chicken/Fish Plate - full Pot 12 W x 13-3/8 D Part No. 8238861 (Not available for split pot)	\$337
Basket, triplet 4-1/4 x 13-1/4 x 5-1/2 Part No. 8030438	\$159	Clean-out Rod 27" long Part No. 8030388	\$83
Basket, twin size 5-7/8 x 12-5/8 x 6-5/8 Part No. 8030271	\$163	Cover, stainless steel - full Pot 14-3/8 W x 19-1/2 D Part No. 1068325	\$220
Basket Hanger, single frypot; 15-3/8 W x 5 H Part No. 2308165	\$89	Cover, stainless steel - split Pot 7-1/2 W x 19-3/8 D Part No. 1068329	\$131
Basket Hanger, 2 & 4 frypots; 31 W x 5 H Part No. 2307495 (2 hangers required for 4 frypots)	\$179	Elevated Top-Off Container Kit	\$748
Basket Hanger, 3 frypots; 46-1/2 W x 5 H Part No. 2307497	\$268	Fish Plate 13" x 13-1/2" x 4-1/2" Part No. 8238065	\$337
Basket Support Rack - full pot 12-1/2 W x 13-3/4 H Part No. 8030132	\$93	Fish Scoop 8-1/8 W x 8-1/2 D with 17-3/8 handle Part No. 8030059	\$96
Basket Hanger, 5 frypots; 31 W x 5 H & 46-1/2 W x 5 H 1 Part No. 2307497 1 Part No. 2307495	\$447	Fish Skimmer 6" square w/ insulated handle Part No. 8030184	\$87
Basket Support Rack - split pot 5-3/4 W x 13-1/2 D Part No. 8030106	\$83	Jug in Box (JIB) Holder - stainless steel (not NSF approved); 10-1/2 x 10-1/2 x 8-1/2; Part No. 8242298	\$282
Brush, L-shaped Tampico 21" L x 2" Diameter Part No. 8030429	\$65	Jug in Box (JIB) Holder Mobile Part No. 8239145	\$195
Brush, L-shaped Teflon 26-3/4" L x 1" Diameter Part No. 8030278	\$78	Splash Shield, Side 19-1/2 W x 11-3/4 H Part No. 8238224	\$113
CASTERS - set of four	\$284	Splash Shield, Bottom	\$20/frypot

NOTES:

- One cord is provided per full or dual split frypot on 3 phase models.
- Plug is an optional accessory on units shipping with cord. **EXCEPTION:** Units shipping to Canada with a cord must have a plug as well.
- Optional plug -- (Domestic: NEMA #15-60P) -- Add \$129 for each full frypot.
- Single phase units must be field wired. No cord or plug provided. Check electrical codes for proper supply line sizing.
- Controller, filter pump and basket lifts are powered by element voltages except 480V fryers.
- All 480 volt models are provided with separate 120 volt cord and plug for filter pump, controller, and/or basket lifts.
- 480V 3 PH option -- Add \$568 per full or dual split frypot.
- No plug or cord is provided single phase fryers.
- Any questions or pricing information other than the above should be referred to **CUSTOMER SERVICE -- TOLL FREE 1-800-221-4583.**

POWER REQUIREMENTS, PER FRYPOT - BASIC DOMESTIC

MODELS	KW	ELEMENTS/FRYPOT			CONTROLS/FRYPOT	FILTER	AUTO TOP-OFF/FRYPOT	BASKET LIFTS/FRYPOT
		VOLTAGE	3 PHASE*	1 PHASE**				
FQE30U	14	208v	39 A	67 A	1 A	5A	1 A	2 A
		240v	34 A	58 A	1 A	4A	1 A	2 A
		480v	17 A	N/A	120v 1 A	120v 8 A	1 A	120v 3 A

* 3PH / 3 wire / plus ground wire ** 1PH / 2 wire / plus ground wire

STANDARD ACCESSORIES

FilterQuick Filtration with ATO Casters Rack-type Basket Support Bottom Splash Shield Cords	Basket Hanger Twin Baskets Filter Starter Kit Oil Management Package* 8GPM Pump
--	---

SPECIAL OIL OPTIONS

SEMI-SOLID/SOLID SHORTENING	\$2,331
FRONT OIL DISCHARGE (Precludes bulk rear oil discharge)	MUST BE SPECIFIED WHEN ORDERED
OIL QUALITY SENSOR	\$2,299

SPREADERS - ADD TO PRICE OF FRYER BATTERY

SPREADER CABINET Call Customer Service for availability and placement.	\$999
---	-------

FILTERING ACCESSORIES

Filter Powder (80, 1oz. Packs) Part No. 8030002	\$100
Filter Paper (16-1/2 x 25-1/2) Box of 100 sheets Part No. 8030445	\$119
Metal Filter Screen * (for built-in filtration) (11-1/8 x 19-1/4)	\$682

*Oil Management Package included at no extra charge.

Includes:

- Set-up for bulk oil
- Frypot covers

Now With
Expanded
Model
Options!



1814 High-Production, Oil-Conserving, Electric Fryers

Conserve Oil, Energy, & Space

- 1. Use 10-15% less hood and floor space** than standard fryer systems.
- 2. Use upwards of 30% less energy** than comparable standard fryer systems.
- 3. Use less oil** reducing operating costs and environmental impact.
 - 20% less than 3 standard 50-lb fryers (120 lbs of oil vs 150 lbs)
 - 15% less than 4 standard 50-lb fryers (170 lbs of oil vs 200 lbs)
- 4. Deliver flexible, high-production cooking** with one or two 18" x 14" x 4-1/4" cooking area(s) that can cook three baskets of food at the same time. Each 18" x 14" x 4-1/4" frypot can produce:
 - 112 lbs. of frozen chicken nuggets/hr
 - 84 lbs. of French fries/hr
 - 66 lbs. of fresh-breaded chicken strips/hr
 - 66 lbs. of dry dredge catfish/hr
 - 96 pieces of fresh-breaded, 8-piece cut chicken/hr
 - 67 lbs. of wings/hr (756 pieces)
- 5. Control food and oil quality with the SMART4U®3000 controller**, which has programmable cook buttons and features that make it easy to produce consistent, great-tasting food. Digital and CM3.5 controller options are also available.
- 6. Save on equipment costs.**
 - Two 1814E fryers do the work of three 50-lb fryers.
 - Two 1814E & one RE17 do the work of four 50-lb fryers.
- 7. Support oil station management** with built-in filtration options, making it easy to preserve oil life and ensure consistent, great-tasting food. 8 GPM pump quickly removes crumbs and sediment, making the filter process quick and effective.
- 8. Optimize heat transfer** with robust, self-standing, ribbon-type, low-watt density electric elements.
- 9. Handle high-sediment foods with ease.** Sloping bottom ensures fast drainage and easy cleaning.

Model shown: 1814E/RE17/1814E



1814E models meet ENERGY STAR® guidelines. All 1814 fryers are part of the Manitowoc EnerLogic® energy program.

HIGH-PRODUCTION OIL-CONSERVING 1814 ELECTRIC FRYERS

11814E FRYER WITHOUT FILTRATION, WITH STAINLESS STEEL FRYPOT, DOOR AND CABINET SIDES							
MODEL NUMBER	DIGITAL	CM3.5 CONTROLLER	SMART4U 3000 CONTROLLER	OIL CAPACITY LBS	COOK AREA W" x L" x D"	ELECTRICAL INPUT	SHIPPING WEIGHT LBS
11814E	\$9,899	\$11,099	\$11,799	60	18 x 14 x 4-1/2	17 kw	255

*Standard with SMART4U 3000 Controller.

11814E FRYERS WITH FILTRATION, STAINLESS STEEL FRYPOTS, DOORS AND CABINET SIDES							
MODEL NUMBER	DIGITAL	CM3.5 CONTROLLER	SMART4U 3000 CONTROLLER	OIL CAPACITY LBS	COOK AREA W" x L" x D"	ELECTRICAL INPUT	SHIPPING WEIGHT LBS
11814EF	\$20,549	\$21,749	\$22,449	(1) 60	(1) 18 x 14 x 4-1/2	(1) 17 kw	255
21814EF	\$31,399	\$33,799	\$35,199	(2) 60	(2) 18 x 14 x 4-1/4	(2) 17 kw	510
31814EF	\$42,299	\$45,899	\$47,999	(3) 60	(3) 18 x 14 x 4-1/4	(3) 17 kw	765
41814EF	\$53,149	\$57,949	\$60,749	(4) 60	(4) 18 x 14 x 4-1/4	(4) 17 kw	1,020
11814E/RE17/ 11814E (W/ FILTER)	\$38,849	\$42,149	\$43,649	2 (60) 1 (50)	(2) 18 x 14 x 4-1/4 (1) 14 x 14 x 3-1/2	(3) 17 kw	907

*Standard with SMART4U 3000 Controller.

STANDARD ACCESSORIES	
Rack-type Basket Support Basket Hangers Twin Baskets Legs (non-filter models)	Filter models have: Filter Starter Kit Drain Safety Switch Casters 8GPM Pump

HIGH-PRODUCTION OIL-CONSERVING 1814 ELECTRIC FRYERS

FRYER ACCESSORIES			
Basket, twin size 5-7/8 x 12-5/8 x 6-5/8 Part No. 8030271	\$163	CASTERS - set of four (filter models)	\$284
Basket, chicken 17-3/4 x 12-3/4 x 11 Part No. 8030441	\$461	Chicken/Fish Plate 11814E 17 W x 13-1/2 D Part No. 2208962	\$344
Basket, dual 8 x 12-5/8 x 7 Part No. 8030437	\$166	Chicken/Fish Plate RE17 13-5/8 W x 14-1/4 D Part No. 2208964	\$344
Basket, full size 17-1/2 x 12-7/8 x 6-1/8 Part No. 8030435	\$252	Clean-out Rod 27" long Part No. 8030197	\$83
Basket, quad 11814E 4-1/2 x 13-1/4 x 6 Part No. 8030357	\$159	Cover, stainless steel 11814E 19 W x 19-3/8 D Part No. 1069620	\$239
Basket, triplet size RE17 4-1/2 x 13-1/4 x 6 Part No. 8030357	\$159	Cover, stainless steel RE17 14-7/8 W x 19-3/8 D Part No. 8063068	\$224
Basket, full 12-3/8 x 12-7/8 x 5-1/4 Part No. 8030099 (can't be used w/ basket lifts)	\$244	Fish Scoop 8-1/8 W x 8-1/2 D with 17-3/8 handle Part No. 8030059	\$96
Basket Hanger Over the flue - 11814 19-7/8 W x 5-1/4 H Part No. 2304318	\$89	Fish Skimmer 6" square w/ insulated handle Part No. 8030184	\$87
Basket Hanger Over the flue - 21814 39-3/4 W x 5-1/4 H Part No. 2308464	\$179	Legs, 6" H, set of four 11814E only (non-filter models)	\$284
Basket Hanger Over the flue 11814/RE17/11814 55-7/8 W x 5-1/4 H Part No. 2308319	\$268	Sediment Tray 17-3/4 x 13-5/8 x 11 Part No. 1086187	\$494
Basket Support Rack 13-5/8 W x 18 D Part No. 8030380	\$111	Splash Shield 1814E 20-5/8 D x 6 H Part No. 8238155	\$246
Brush, L-shaped Tampico 21" L x 2" Diameter Part No. 8030429	\$65	Splash Shield RE17 20 D x 6-1/8 H Part No. 8236559	\$113
Brush, L-shaped Teflon 26-3/4" L x 1" Diameter Part No. 8030278	\$78	Top Connecting Strip Part No. 2308819	\$139

EXTERNAL OIL DISCHARGE OPTIONS	
External oil discharge - available on built-in filter batteries of 2 or more frypots. Must specify front or rear connection. Front connection comes with 5' washdown hose.	Front \$1,593
	Rear \$1,082
External oil discharge kit (rear only) - available on batteries with filter*	CALL KITCHENCARE AT 1-844-724-2273
Bulk oil (dispose and fresh fill) on batteries with built-in filtration	\$2,000

* Requires field service installation

FILTERING ACCESSORIES	
Filter Powder (80, 1oz. Packs) Part No. 8030002	\$100
Filter Paper (22 x 34) Box of 100 sheets Part No. 8030289	\$217
Filter Screen (high sediment) 8-1/4 W x 14 D Part No. 8239116	\$299

POWER REQUIREMENTS, PER FRYPOT - BASIC DOMESTIC					
MODEL	KW	ELEMENTS/FRYPOT		CONTROLS/ FRYPOT	FILTER
		VOLTAGE	3 PHASE*		
11814E	17	208v	48 A	1 A 1 A 120v 1 A	N/A
21814E		240v	41 A		5A
		480v	21 A		4A
					120v 8 A
RE17	17	208v	48 A	1 A 1 A 120v 1 A	5 A
		240v	41 A		4 A
		480v	21 A		120v 8 A

*3PH / 3 wire / plus ground wire.

NOTES:

- One cord is provided per frypot.
- Plug is optional accessory on units shipping with cord. **EXCEPTION:** Units shipping to Canada with a cord must have a plug as well.
- Optional plug -- (Domestic: NEMA #15-60P) -- Add \$129 for each full or dual split frypot.
- Controller, filter pump and basket lifts are powered by element voltages except 480V fryers.
- All 480 volt models are provided with separate 120V cord and plug for filter pump, controller and/or basket lifts.
- 480V 3PH option -- Add \$568 per frypot.
- No plug or cord is provided on single phase fryers.
- Any questions or pricing information other than the above should be referred to **CUSTOMER SERVICE -- TOLL FREE 1-800-221-4583.**



OCF30

OIL CONSERVING FRYERS

OCF30™ Series Electric Fryers

40% Less Oil, 10% Less Energy, Outstanding Results

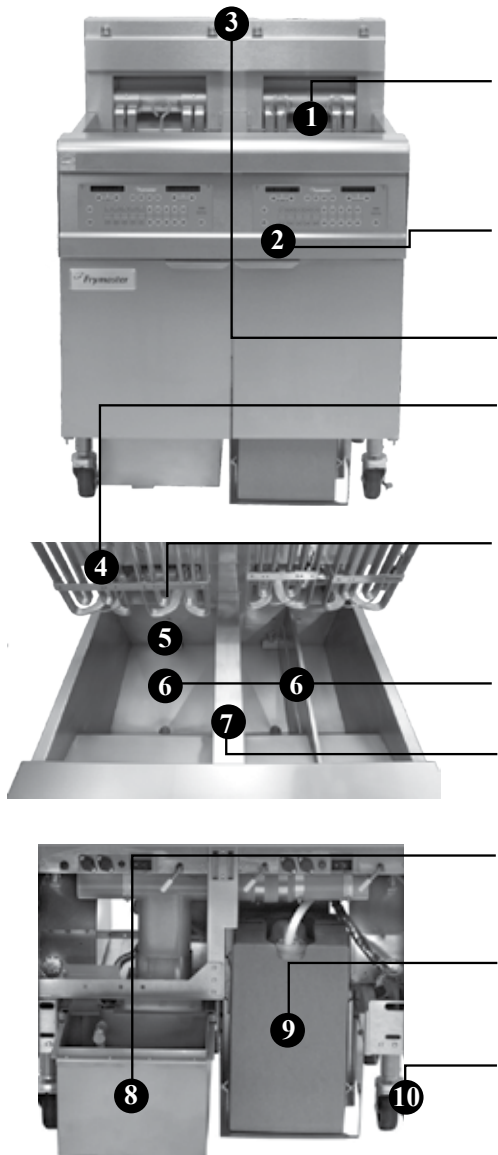

- 
1. **30-lb open frypot design** requires 40% less oil and ensures quick and easy cleaning. Saves money, time and labor.
 2. **SMART4U® 3000 controller** helps control food and oil quality, oil life, and equipment performance.
 3. **Sturdy basket hangers** are durable and easy to clean.
 4. **Safe, self-standing heating elements** ensure industry leading energy efficiency and sealed rotation housing protects against oil migration.
 5. **High limit auto reset** requires no tools or operator intervention and an **audible alarm** alerts if a second drain valve is opened.
 6. **Robust product line** offers full and split frypots.
 7. **Independent frypot construction** allows convenient frypot repairs in the field if needed.
 8. **FootPrint PRO® built-in filtration** preserves oil life and ensures consistent, great-tasting food.
 9. **Oil Attendant® auto fill option** senses the oil level and adds oil as needed from an in-cabinet supply.
 10. **Adjustable leveling casters** accommodate all kitchen designs and floor types.



OCF30E fryers meet ENERGY STAR® guidelines for high efficiency. All OCF30E fryers are part of the Manitowoc EnerLogic® program.

OIL-CONSERVING OCF30 ELECTRIC FRYERS

OCF30 FRYERS WITH FILTRATION, MANUAL TOP-OFF, STAINLESS STEEL FRYPOT, DOOR AND CABINET					
MODEL NUMBER	SMART4U 3000 CONTROLLER	OIL CAPACITY LBS	COOK AREA W" x L" x D"	ELECTRICAL INPUT	SHIPPING WEIGHT LBS
FPEL114C -- FULL POT	\$16,399	30	13 x 14 x 3-3/4	14 kw	255

*Standard with SMART4U 3000 Controller.

NOTES:

- ATO not available on single units.

OCF30 FRYER BATTERIES WITH FILTRATION, AUTO TOP-OFF, STAINLESS STEEL FRYPOTS, DOORS AND CABINET					
MODEL NUMBER	SMART4U 3000 CONTROLLER	OIL CAPACITY LBS	COOK AREA W" x L" x D"	ELECTRICAL INPUT	SHIPPING WEIGHT LBS
FPEL214CA -- FULL POT	\$27,499	(2) 30	(2) 13 x 14 x 3-3/4	14 kw	535
FPEL314CA -- FULL POT	\$38,099	(3) 30	(3) 13 x 14 x 3-3/4	14 kw	667
FPEL414CA -- FULL POT	\$48,699	(4) 30	(4) 13 x 14 x 3-3/4	14 kw	978

*Standard with SMART4U 3000 Controller.

NOTES:

- Split frypots - Add \$2,000 for each split frypot.
- Basket Lifts - Add \$2,500 for each frypot (full or split).
- Casters included in pricing.
- Can substitute CM3.5 for 3000 controller for no additional cost.
- Tandem basket lifts - Add \$80 each frypot (full or split).
- Any questions or pricing information other than the above should be referred to **CUSTOMER SERVICE -- TOLL FREE 1-800-221-4583**.

STANDARD ACCESSORIES	
Built-in Filtration	Basket Hanger
Casters	Twin Baskets
Rack-type Basket Support	Cords
ATO (except FPEL114C)	8GPM Pump

OIL-CONSERVING OCF30 ELECTRIC FRYERS

FRYER ACCESSORIES			
Basket, full size 12-3/8 x 12-7/8 x 5-1/4 Part No. 8030099 (can't be used w/ basket lifts)	\$244	Chicken/Fish Plate - full pot 12 W x 13-3/8 D Part No. 8238861 (Not available for split pot)	\$337
Basket, triplet 4-1/4 x 13-1/4 x 5-1/2 Part No. 8030438	\$159	Clean-out Rod 27" long Part No. 8030197	\$83
Basket, twin size 5-7/8 x 12-5/8 x 6-5/8 Part No. 8030271	\$163	Cover, stainless steel - full Pot 14-3/8 W x 19-1/2 D Part No. 1068325	\$220
Basket Hanger, single frypot; 15-3/8 W x 5 H Part No. 2308165	\$89	Cover, stainless steel - split Pot 7-1/2 W x 19-3/8 D Part No. 1068329	\$131
Basket Hanger, 2 & 4 frypots; 31 W x 5 H Part No. 2307495	\$179	Fish Plate 13" x 13-1/2" x 4-1/2" Part No. 8238065	\$337
Basket Hanger, 3 frypots; 46-1/2 W x 5 H Part No. 2307497	\$268	Fish Scoop 8-1/8 W x 8-1/2 D with 17-3/8 handle Part No. 8030059	\$96
Basket Support Rack - full pot 12-1/2 W x 13-3/4 H Part No. 8030132	\$93	Fish Skimmer 6" square w/ insulated handle Part No. 8030184	\$87
Basket Support Rack - split pot 5-3/4 W x 13-1/2 D Part No. 8030106	\$83	Jug in Box (JIB) Holder - stainless steel (not NSF approved); 10-1/2 x 10-1/2 x 8-1/2; Part No. 8242298	\$282
Brush, L-shaped Tampico 21" L x 2" Diameter Part No. 8030429	\$65	Jug in Box (JIB) Holder Mobile Part No. 8239145	\$195
Brush, L-shaped Teflon 26-3/4" L x 1" Diameter Part No. 8030278	\$78	Splash Shield 19-1/2 W x 11-3/4 H Part No. 8238224	\$113
CASTERS - set of four Call Customer Service to specify model	\$284		

SPECIAL OIL OPTIONS	
BULK OIL (REAR ONLY)(FILTER MODELS ONLY)	\$2,000
BULK OIL KIT (REAR ONLY) *(FILTER MODELS ONLY)	CALL KITCHENCARE AT 1-844-724-2273
SEMI-SOLID/SOLID SHORTENING	\$2,331

* Requires field service installation

SPREADERS - ADD TO PRICE OF FRYER(S)	
SPREADER CABINET Call Customer Service for availability and placement.	\$999

FILTERING ACCESSORIES	
Filter Powder (80, Toz. Packs) Part No. 8030002	\$100
Filter Paper (19-1/2 x 27-1/2) Box of 100 sheets Part No. 8030170	\$119
Metal Filter Screen * (for built-in filtration) (11-1/8 x 19-1/4)	\$682

NOTES:

- One cord is provided per full or dual split frypot on 3 phase models.
- Plug is an optional accessory on units shipping with cord. **EXCEPTION:** Units shipping to Canada with a cord must have a plug as well.
- Optional plug -- (Domestic: NEMA #15-60P) -- Add \$129 for each full frypot.
- Single phase units must be field wired. No cord or plug provided. Check electrical codes for proper supply line sizing.
- Controller, filter pump and basket lifts are powered by element voltages except 480V fryers.
- All 480 volt models are provided with separate 120 volt cord and plug for filter pump, controller, and/or basket lifts.
- 480V 3 PH option -- Add \$568 per full or dual split frypot.
- No plug or cord is provided on single phase fryers.
- Any questions or pricing information other than the above should be referred to **CUSTOMER SERVICE -- TOLL FREE 1-800-221-4583.**

POWER REQUIREMENTS, PER FRYPOT - BASIC DOMESTIC

MODELS	KW	ELEMENTS/FRYPOT			CONTROLS/FRYPOT	FILTER	AUTO TOP-OFF/ FRYPOT	BASKET LIFTS/ FRYPOT
		VOLTAGE	3 PHASE*	1 PHASE**				
FPFLCA	14	208v	39 A	67 A	1 A	5A	1 A	2 A
		240v	34 A	58 A	1 A	4A	1 A	2 A
		480v	17 A	N/A		120v 1 A	120v 8 A	1 A

* 3PH / 3 wire / plus ground wire
** 1PH / 2 wire / plus ground wire



RE High-Efficiency Electric Fryers

Put Every kw to Work at Maximum Efficiency

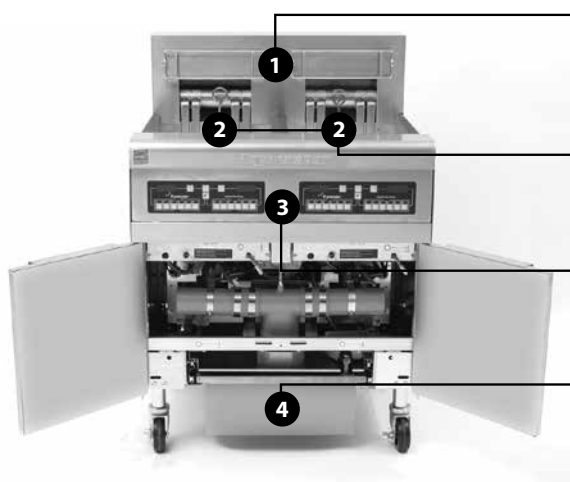

- 1. Deliver award winning performance.** The RE fryers have been recognized by the Electric Foodservice Council with a President Choice Award for outstanding contribution to the advancement of electric foodservice equipment.
- 2. Help keep the kitchen cool.** With more energy going into the oil, there is less heat going into the ambient air which keeps workers comfortable and reduces demand on HVAC.
- 3. Have industry leading energy efficiency** with ASTM ratings greater than 83%. RE fryers are ENERGY STAR® rated and qualify for energy saving rebates.
- 4. Can significantly extend oil life, saving thousands of dollars annually on oil costs** with built-in filtration options that make it easy to preserve oil life and ensure great tasting food.

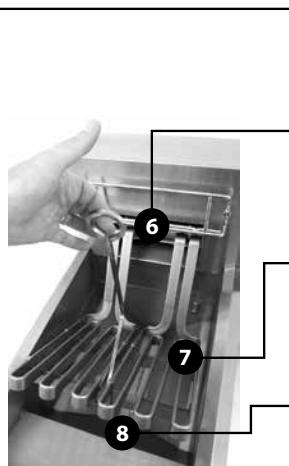
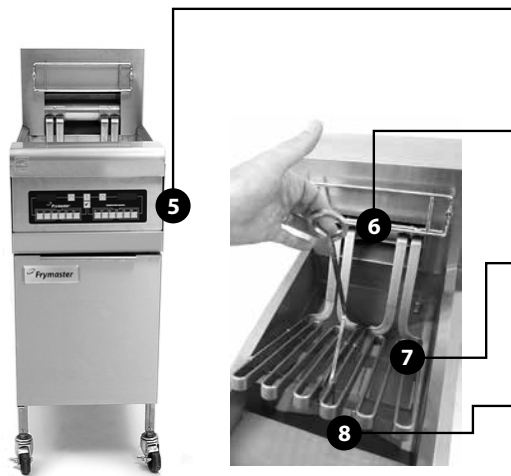

- 5. Support a broad range of frying needs** with 14kw, 17kw, and 22kw models, controller options that add features all the way to cook compensation, and basket lift options.
- 6. Protect and conserve with safe, self-standing, swing-up, flat-bar heating elements** that allow a highly efficient and uniform transfer of heat into the oil. A sealed rotation housing protects against oil migration.
- 7. Produce consistent, high quality food time after time.** RTD, temperature probe and analog* controller, deliver precise heat response, safeguarding oil life and producing a uniformly-cooked product.
- 8. Are easy to clean.** Open frypot design and sturdy self-standing elements allow safe access to every inch of the frypot.

RE Fryers deliver a lifetime of performance.

*Not available for CE.



RE14, 17 and 22 fryers meet ENERGY STAR guidelines for high efficiency. All RE14, 17 and 22 fryers are part of the Manitowoc EnerLogic® program.

ULTRA HIGH EFFICIENCY RETC ELECTRIC FryERS

RETC FryERS WITHOUT FILTRATION, WITH STAINLESS STEEL FryPOT, DOOR AND CABINET

MODEL NUMBER	CM 3.5 CONTROLLER	OIL CAPACITY LBS	COOK AREA W" x L" x D"	ELECTRICAL INPUT	SHIPPING WEIGHT LBS
RE14TC FULL POT	\$11,549	50	14 x 15-1/2 x 3-3/4	14 kw	190 - 214
RE17TC FULL POT	\$12,749	50	14 x 15-1/2 x 3-3/4	17 kw	190 - 214
RE22TC FULL POT	\$13,599	50	14 x 15-1/2 x 3-3/4	22 kw	190 - 214

*Standard with CM3.5 controller

14 KW RETC FryERS WITH FILTRATION, STAINLESS STEEL FryPOTS, DOORS AND CABINET

MODEL NUMBER	CM 3.5 CONTROLLER	OIL CAPACITY LBS	COOK AREA W" x L" x D"	ELECTRICAL INPUT	SHIPPING WEIGHT LBS
FPRE214TC FULL POT	\$33,599	(2) 50	(2) 14 x 15-1/2 x 3-3/4	(2) 14 kw	552
FPRE314TC FULL POT	\$45,499	(3) 50	(3) 14 x 15-1/2 x 3-3/4	(3) 14 kw	618
FPRE414TC FULL POT	\$57,449	(4) 50	(4) 14 x 15-1/2 x 3-3/4	(4) 14 kw	780
FPRE514TC FULL POT	\$69,399	(5) 50	(5) 14 x 15-1/2 x 3-3/4	(5) 14 kw	838
FPRE614TC FULL POT	\$81,349	(6) 50	(6) 14 x 15-1/2 x 3-3/4	(6) 14 kw	2 @ 618

*Standard with CM3.5 controller

NOTES:

- Filter price included.
- Casters included in pricing.

17 KW RETC FryERS WITH FILTRATION, STAINLESS STEEL FryPOTS, DOORS AND CABINET

MODEL NUMBER	CM 3.5 CONTROLLER	OIL CAPACITY LBS	COOK AREA W" x L" x D"	ELECTRICAL INPUT	SHIPPING WEIGHT LBS
FPRE217TC FULL POT	\$36,049	(2) 50	(2) 14 x 15-1/2 x 3-3/4	(2) 17 kw	552
FPRE317TC FULL POT	\$49,249	(3) 50	(3) 14 x 15-1/2 x 3-3/4	(3) 17 kw	618
FPRE417TC FULL POT	\$62,399	(4) 50	(4) 14 x 15-1/2 x 3-3/4	(4) 17 kw	780
FPRE517TC FULL POT	\$75,599	(5) 50	(5) 14 x 15-1/2 x 3-3/4	(5) 17 kw	838
FPRE617TC FULL POT	\$88,799	(6) 50	(6) 14 x 15-1/2 x 3-3/4	(6) 17 kw	2 @ 618

*Standard with CM3.5 controller

NOTES:

- Filter price included.
- Casters included in pricing.

22 KW RETC FryERS WITH FILTRATION, STAINLESS STEEL FryPOTS, DOORS AND CABINET

MODEL NUMBER	CM 3.5 CONTROLLER	OIL CAPACITY LBS	COOK AREA W" x L" x D"	ELECTRICAL INPUT	SHIPPING WEIGHT LBS
FPRE222TC FULL POT	\$37,799	(2) 50	(2) 14 x 15-1/2 x 3-3/4	(2) 22 kw	552
FPRE322TC FULL POT	\$51,799	(3) 50	(3) 14 x 15-1/2 x 3-3/4	(3) 22 kw	618
FPRE422TC FULL POT	\$65,799	(4) 50	(4) 14 x 15-1/2 x 3-3/4	(4) 22 kw	780
FPRE522TC FULL POT	\$79,799	(5) 50	(5) 14 x 15-1/2 x 3-3/4	(5) 22 kw	838
FPRE622TC FULL POT	\$93,849	(6) 50	(6) 14 x 15-1/2 x 3-3/4	(6) 22 kw	2 @ 618

*Standard with CM3.5 controller

NOTES:

- Filter price included.
- Casters included in pricing.

NOTES -- RETC AND FPRETC:

- Split frypots - Add \$2,000 for each split frypot.
- Basket Lifts - Add \$2,500 for each frypot (full or split).
- Casters included in basket lift pricing.
- Standard supplies for all filter systems consist of sample packages of filter powder and paper, one filter brush and one clean-out rod.

STANDARD ACCESSORIES

TRIAC Controls	Basket Hanger
Automatic Melt Cycle	Twin Baskets
Boil Out Temperature Control	Casters (filter fryers)
Legs (non-filter fryers)	Cords (14 kw & 17 kw)
Rack-type Basket Support	Terminal Block Box (22 kw)

ULTRA HIGH EFFICIENCY RETC ELECTRIC FRYERS

FRYER ACCESSORIES			
Basket, full size 12-3/8 x 12-7/8 x 5-1/4 Part No. 8030099 (can't be used w/ basket lifts)	\$244	Clean-out Rod 27" long Part No. 8030197	\$83
Basket, twin size 5-7/8 x 12-5/8 x 6-5/8 Part No. 8030271	\$163	Cover, stainless steel - Full pot 14-5/8 W x 19-3/8 D Part No. 8063068	\$224
Basket, triplet size 4-1/2 x 13-1/4 x 6 Part No. 8030357	\$159	Cover, stainless steel - Split pot 9 W x 19-1/2 D Part No. 8063071	\$131
Basket Hanger 12-1/2 W x 3-1/2 H Part No. 8102793	\$98	Fish scoop 8-1/8 W x 8-1/2 D with 17-3/8 handle Part No. 8030059	\$96
Basket Support Rack - Full pot 12-1/2 W x 13-3/4 H Part No. 8030132	\$93	Fish skimmer 6" square w/ insulated handle Part No. 8030184	\$87
Basket Support Rack - Split pot 5-3/4 W x 13-1/2 D Part No. 8030106	\$83	Legs - 8-1/2"H, set of four	\$284
Basket Support Screen - Full Pot* 12-1/2 W x 13-3/4 H Part No. 8030136	\$129	Sediment tray - Full pot 10-1/2 x 11-5/8 x 4 Part No. 8030358	\$441
Brush, L-shaped Tampico 21 L x 2" Diameter Part No. 8030429	\$65	Sediment tray - Split pot 4-5/8 x 13-7/8 x 4 Part No. (L) 8030360 Part No. (R) 8030359	\$337
Brush, L-shaped Teflon 26-3/4 L x 1" Diameter Part No. 8030278	\$78	Splash Shield 20 D x 6-1/8 H Part No. 8236559	\$113
CASTERS - set of 4	\$284	Top Connecting Strip 8235810	\$139
Chicken/Fish Plate - Full pot 13-5/8 W x 14-1/4 D Part No. 2208964 (not available for split pot)	\$344		

* Basket support screen - full frypot only. If needed in lieu of standard rack type when purchasing new fryers, ADD \$65 per frypot.

NOTES:

- TC models not available in 480V.
- One cord is provided per full or dual split frypot on 3 phase (14 kw and 17 kw models).
- Plug is optional accessory on units shipping with a cord. **EXCEPTION:** Units shipping to Canada with a cord must have a plug as well.
- Optional plug -- (Domestic: NEMA #15-60P) -- Add \$129 for each full frypot.
- All 22 kw and single phase units must be field wired. No plug or cord provided. Check electrical code for proper supply line sizing.
- Controller, filter pump and basket lifts are powered by element voltages.
- RETC models not available in 480V.
- Any questions or pricing information other than the above should be referred to **CUSTOMER SERVICE -- TOLL FREE 1-800-221-4583.**

FILTERING ACCESSORIES	
Cone Holder (10" Diameter) (non-filter models only) Part No. 8030072	\$70
Filter Cones (10" Diameter- box of 50) (non-filter models only) Part No. 8030042	\$85
Filter Powder (80, 1oz. Packs) Part No. 8030002	\$100
Filter Paper (19-1/2 x 27-1/2) Box of 100 sheets Part No. 8030170	\$119
Metal Filter Screen * (fits FootPrint PRO filter) 11-1/8 x 19-1/4 Part No. 8102800	\$682

* Must be requested at time of fryer order.

SPREADERS - ADD TO PRICE OF FRYER(S)	
SPREADER CABINET Call Customer Service for availability and placement.	\$999

EXTERNAL OIL DISCHARGE	
External oil discharge -- available on built-in filter batteries of two or more frypots or a frypot spreader -- must specify front or rear connection. Front connection comes with 5ft. washdown hose.	Front \$1,593 Rear \$1,082

POWER REQUIREMENTS, PER FRYPOT - BASIC DOMESTIC							
MODELS	KW	ELEMENTS/FRYPOT			CONTROLS/FRYPOT	FILTER	BASKET LIFTS/FRYPOT
		VOLTAGE	3 PHASE*	1 PHASE**			
RE14TC	14	208v 240v	39 A 34 A	67 A 58 A	1 A 1 A	5 A 4 A	2 A 2 A
RE14-2TC	(2) 7						
RE17TC	17	208v 240v	48 A 41 A	82 A 71 A	1 A 1 A	5 A 4 A	2 A 2 A
RE17-2TC	(2) 8.5						
RE22TC	22	208v 240v	61 A 53 A	106 A 92 A	1 A 1 A	5 A 4 A	2 A 2 A
RE22-2TC	(2) 11						

* 3PH / 3 wire / plus ground wire ** 1PH / 2 wire / plus ground wire

HIGH EFFICIENCY RE ELECTRIC FRYERS

RE FRYERS WITHOUT FILTRATION, WITH STAINLESS STEEL FRYPOT, DOOR AND CABINET

MODEL NUMBER	DIGITAL CONTROLLER	CM 3.5 CONTROLLER	SMART4U 3000 CONTROLLER	OIL CAPACITY LBS	COOK AREA W" x L" x D"	ELECTRICAL INPUT	SHIPPING WEIGHT LBS
RE14 FULL POT	\$8,749	\$9,949	\$10,640	50	14 X 15-1/2 X 3-1/2	14 kw	190 - 214
RE17 FULL POT	\$9,949	\$11,149	\$11,849	50	14 X 15-1/2 x 3-1/2	17 kw	190 - 214
RE22 FULL POT	\$10,899	\$12,099	\$12,799	50	14 X 15-1/2 x 3-1/2	22 kw	190 - 214

*Standard with Digital controller.

14 KW FRYERS WITH FILTRATION, STAINLESS STEEL FRYPOT(S), DOOR(S) AND CABINET

MODEL NUMBER	DIGITAL CONTROLLER	CM 3.5 CONTROLLER	SMART4U 3000 CONTROLLER	OIL CAPACITY LBS	COOK AREA W" x L" x D"	ELECTRICAL INPUT	SHIPPING WEIGHT LBS
FPRE114 FULL POT	\$19,049	\$20,249	\$20,949	50	14 X 15-1/2 X 3-1/2	14 kw	277
FPRE214 FULL POT	\$28,399	\$30,799	\$32,199	(2) 50	(2)14 X 15-1/2 X 3-1/2	(2) 14 kw	459
FPRE314 FULL POT	\$37,749	\$41,349	\$43,449	(3) 50	(3) 14 X 15-1/2 x 3-1/2	(3) 14 kw	612
FPRE414 FULL POT	\$47,099	\$51,899	\$54,699	(4) 50	(4) 14 X 15-1/2 X 3-1/2	(4) 14 kw	811
FPRE514 FULL POT	\$56,449	\$62,449	\$65,949	(5) 50	(5) 14 X 15-1/2 x 3-1/2	(5) 14 kw	957
FPRE614 FULL POT	\$65,849	\$73,049	\$77,249	(6) 50	(6)14 X 15-1/2 X 3-1/2	(6) 14 kw	2 @ 612

*Standard with Digital controller.

NOTES:

- Filter price included.
- Casters included in pricing.

17 KW FRYERS WITH FILTRATION, STAINLESS STEEL FRYPOT(S), DOOR(S) AND CABINET

MODEL NUMBER	DIGITAL CONTROLLER	CM 3.5 CONTROLLER	SMART4U 3000 CONTROLLER	OIL CAPACITY LBS	COOK AREA W" x L" x D"	ELECTRICAL INPUT	SHIPPING WEIGHT LBS
FPRE117 FULL POT	\$20,249	\$21,449	\$22,149	50	14 X 15-1/2 X 3-1/2	17 kw	277
FPRE217 FULL POT	\$30,749	\$33,149	\$34,549	(2) 50	(2) 14 X 15-1/2 X 3-1/2	(2) 17 kw	459
FPRE317 FULL POT	\$41,249	\$44,849	\$46,949	(3) 50	(3)14 X 15-1/2 x 3-1/2	(3) 17 kw	612
FPRE417 FULL POT	\$51,749	\$56,549	\$59,349	(4) 50	(4) 14 X 15-1/2 X 3-1/2	(4) 17 kw	811
FPRE517 FULL POT	\$62,249	\$68,249	\$71,749	(5) 50	(5) 14 X 15-1/2 x 3-1/2	(5) 17 kw	957
FPRE617 FULL POT	\$72,749	\$79,949	\$84,149	(6) 50	(6) 14 X 15-1/2 X 3-1/2	(6) 17 kw	1,098

*Standard with Digital controller.

NOTES:

- Filter price included.
- Casters included in pricing.

22 KW FRYERS WITH FILTRATION, STAINLESS STEEL FRYPOT(S), DOOR(S) AND CABINET

MODEL NUMBER	DIGITAL CONTROLLER	CM 3.5 CONTROLLER	SMART4U 3000 CONTROLLER	OIL CAPACITY LBS	COOK AREA W" x L" x D"	ELECTRICAL INPUT	SHIPPING WEIGHT LBS
FPRE122 FULL POT	\$21,199	\$22,399	\$23,099	50	14 X 15-1/2 X 3-1/2	22 kw	277
FPRE222 FULL POT	\$32,500	\$34,900	\$36,300	(2) 50	(2) 14 X 15-1/2 X 3-1/2	(2) 22 kw	459
FPRE322 FULL POT	\$44,049	\$47,649	\$49,749	(3) 50	(3)14 X 15-1/2 x 3-1/2	(3) 22kw	612
FPRE422 FULL POT	\$55,449	\$60,249	\$63,049	(4) 50	(4) 14 X 15-1/2 X 3-1/2	(4) 22 kw	811
FPRE522 FULL POT	\$66,849	\$72,849	\$76,349	(5) 50	(5) 14 X 15-1/2 x 3-1/2	(5) 22 kw	957
FPRE622 FULL POT	\$78,299	\$85,499	\$89,699	(6) 50	(6) 14 X 15-1/2 X 3-1/2	(6) 22 kw	1,098

*Standard with Digital controller.

NOTES:

- Filter price included.
- Casters included in pricing.

NOTES -- RE AND FPRE FRYERS:

- Add \$2,000 for each split frypot.
- Add \$2,500/frypot for basket lifts (not available with analog or digital controller). Casters included in basket lift pricing.
- Standard supplies for all filter systems consist of sample packages of filter powder and paper, one filter brush and one clean-out rod.

STANDARD ACCESSORIES

Automatic Melt Cycle	Twin Baskets
Boil Out Temperature Control	Casters (filter fryers)
Legs (non-filter fryers)	Cords (14 kw & 17 kf)
Rack-type Basket Support	Terminal Block Box (22 kw)
Basket Hanger	

HIGH EFFICIENCY RE ELECTRIC FRYERS

FRYER ACCESSORIES			
Basket, full size 12-3/8 x 12-7/8 x 5-1/4 Part No. 8030099 <small>(can't be used w/ basket lifts)</small>	\$244	Clean-out Rod 27" long Part No. 8030197	\$83
Basket, twin size 5-7/8 x 12-5/8 x 6-5/8 Part No. 8030271	\$163	Cover, stainless steel - full pot 14-5/8 W x 19-3/8 D Part No. 8063068	\$224
Basket, triplet size 4-1/2 x 13-1/4 x 6 Part No. 8030357	\$159	Cover, stainless steel - split pot 9 W x 19-1/2 D Part No. 8063071	\$131
Basket Hanger 12-1/2 W x 3-1/2 H Part No. 8102793	\$98	Fish Scoop 8-1/8 W x 8-1/2 D with 17-3/8 handle Part No. 8030059	\$96
Basket Support Rack - full pot 12-1/2 W x 13-3/4 H Part No. 8030132	\$93	Fish Skimmer 6" square w/ insulated handle Part No. 8030184	\$87
Basket Support Rack - split pot 5-3/4 W x 13-1/2 D Part No. 8030106	\$83	Legs - 8-1/2" H, set of four, adjustable	\$284
Basket Support Screen - full Pot * 12-1/2 W x 13-3/4 H Part No. 8030136	\$129	Sediment tray - full pot 10-1/2 x 11-5/8 x 4 Part No. 8030358	\$441
Brush, L-shaped Tampico 21" L x 2" Diameter Part No. 8030429	\$65	Sediment tray - split pot 4-5/8 x 13-7/8 x 4 Part No. (L) 8030360 Part No. (R) 8030359	\$337
Brush, L-shaped Teflon 26-3/4" L x 1" Diameter Part No. 8030278	\$78	Splash Shield 20 D x 6-1/8 H Part No. 8236559	\$113
CASTERS - set of four Call Customer Service to specify model	\$284	Top Connecting Strip 8235810	\$139
Chicken/Fish Plate - full pot 13-5/8 W x 14-1/4 D Part No. 2208964 <small>(not available for split pot)</small>	\$344		

* Basket support screen - full frypot only. If needed in lieu of standard rack type when purchasing new fryers, Add \$65 per frypot.

NOTES:

- One cord is provided per full and dual split frypot on 3 phase 14 kw and 17 kw models.
- Plug is an optional accessory on units shipping with a cord. **EXCEPTION:** Units shipping to Canada with a cord must have a plug as well.
- Optional plug -- (Domestic: NEMA #15-60P) -- Add \$129 for each full frypot.
- All 22 kw and single phase units must be field wired. No plug or cord provided. Check electrical code for proper supply line sizing.
- Single phase fryers with built-in filter are available in 240V and 208V only.
- Controller, filter pump and basket lifts are powered by element voltages except 480V fryers.
- All 480V models are provided with separate 120 volt cord and plug for filter pump, and/or controller, and/or basket lifts.
- 480V 3PH option -- Add \$568 per full or dual split frypot
- No plug or cord is provided on single phase fryers.
- Any questions or pricing information other than the above should be referred to **CUSTOMER SERVICE**
-- **TOLL FREE 1-800-221-4583.**

SPREADERS - ADD TO PRICE OF FRYER(S)	
SPREADER CABINET Call Customer Service for availability and placement.	\$999

FILTERING ACCESSORIES	
Cone Holder (non-filter models only) (10" Diameter) Part No. 8030072	\$70
Filter Cones (10" Diameter- box of 50) Part No. 8030042	\$85
Filter Powder (80, 1oz. Packs) Part No. 8030002	\$100
Filter Paper (19-1/2 x 27-1/2) Box of 100 sheets Part No. 8030170	\$119
Metal Filter Screen * (fits FootPrint PRO filter) 11-1/8 x 19-1/4 Part No. 8102800	\$682

* Must be requested at time of fryer order.

EXTERNAL OIL DISCHARGE	
External oil discharge -- available on built-in filter batteries of two or more frypots or a frypot spreader -- must specify front or rear connection. Front connection comes with 5ft. washdown hose.	Front \$1,593 Rear \$1,082

POWER REQUIREMENTS, PER FRYPOT - BASIC DOMESTIC							
MODELS	KW	ELEMENTS/FRYPOT			CONTROLS/FRYPOT	FILTER	BASKET LIFTS/FRYPOT
		VOLTAGE	3 PHASE*	1 PHASE**			
RE14	14	208v	39 A	67 A	1 A 1 A 120v 1 A	5A 4A 120v 8 A	2 A 2 A 120v 3 A
		240v	34 A	58 A			
		480v	17 A	N/A			
RE14-2	(2) 7						
RE17	17	208v	48 A	82 A	1 A 1 A	5 A 4 A	2 A 2 A
		240v	41 A	71 A			
		480v	21 A	N/A			
RE17-2	(2) 8.5						
RE22	22	208v	61 A	106 A	1 A 1 A 120v 1 A	5 A 4 A 120v 8 A	2 A 2 A 120v 3 A
		240v	53 A	92 A			
		480v	22 A	N/A			
RE22-2	(2) 11						

* 3PH / 3 wire / plus ground wire ** 1PH / 2 wire / plus ground wire

HIGH PRODUCTION HIGH EFFICIENCY RE80 ELECTRIC FRYERS

17 KW FRYER WITHOUT FILTRATION, WITH STAINLESS STEEL FRYPOT, DOOR AND CABINET SIDES

MODEL NUMBER	DIGITAL CONTROLLER	CM3.5 CONTROLLER	SMART4U 3000 CONTROLLE	OIL CAPACITY LBS	COOK AREA W" x L" x D"	ELECTRICAL INPUT	SHIPPING WEIGHT LBS
RE180 FULL POT	\$12,349	\$13,549	\$14,249	80	18 x 18 x 5	17 kw	285

*Standard with Digital controller.

21 KW FRYER WITHOUT FILTRATION, WITH STAINLESS STEEL FRYPOT, DOOR AND CABINET SIDES

MODEL NUMBER	DIGITAL CONTROLLER	CM3.5 CONTROLLER	SMART4U 3000 CONTROLLE	OIL CAPACITY LBS	COOK AREA W" x L" x D"	ELECTRICAL INPUT	SHIPPING WEIGHT LBS
RE180 FULL POT	\$13,699	\$14,899	\$15,599	80	18 x 18 x 5	21 kw	285

*Standard with Digital controller.

17 KW FRYERS WITH FILTRATION, STAINLESS STEEL FRYPOT(S), DOOR(S) AND CABINET SIDES

MODEL NUMBER	DIGITAL CONTROLLER	CM3.5 CONTROLLER	SMART4U 3000 CONTROLLE	OIL CAPACITY LBS	COOK AREA W" x L" x D"	ELECTRICAL INPUT	SHIPPING WEIGHT LBS
FPRE180 FULL POT	\$23,399	\$24,599	\$25,299	80	18 x 18 x 5	17 kw	359
FPRE280 FULL POT	\$37,299	\$39,699	\$41,099	(2) 80	(2) 18 x 18 x 5	17 kw	617
FPRE380 FULL POT	\$51,199	\$54,799	\$56,899	(3) 80	(3) 18 x 18 x 5	17 kw	816
FPRE480 FULL POT	\$65,099	\$69,899	\$72,699	(4) 80	(4) 18 x 18 x 5	17 kw	1,044

*Standard with Digital controller.

NOTES:

- Filter price included.
- Casters included in pricing.
- Standard filter supplies include sample packages of filter powder and paper, one filter brush and one clean-out rod and gloves.
- Add \$2,500/frypot for basket lifts (not available with digital controller)
- Tandem basket lifts - Add \$80 each frypot (full or split).
- Split pots not available.

21 KW FRYERS WITH FILTRATION, STAINLESS STEEL FRYPOT, DOOR(S) AND CABINET SIDES

MODEL NUMBER	DIGITAL CONTROLLER	CM3.5 CONTROLLER	SMART4U 3000 CONTROLLE	OIL CAPACITY LBS	COOK AREA W" x L" x D"	ELECTRICAL INPUT	SHIPPING WEIGHT LBS
FPRE180 FULL POT	\$24,799	\$25,999	\$26,699	80	18 x 18 x 5	21 kw	359
FPRE280 FULL POT	\$40,249	\$42,649	\$44,049	(2) 80	(2) 18 x 18 x 5	21 kw	617
FPRE380 FULL POT	\$55,699	\$59,299	\$61,399	(3) 80	(3) 18 x 18 x 5	21 kw	816
FPRE480 FULL POT	\$71,149	\$75,949	\$78,749	(4) 80	(4) 18 x 18 x 5	21 kw	1,044

*Standard with Digital controller.

NOTES:

- Filter price included.
- Casters included in basket lift pricing
- Standard filter supplies include sample packages of filter powder and paper, one filter brush and one clean-out rod and gloves.
- Add \$2,500/frypot for basket lifts (not available with digital controller). Casters included in pricing.
- Tandem basket lifts - Add \$80 each frypot (full or split).
- Split pots not available.

STANDARD ACCESSORIES

Automatic Melt Cycle	Screen-type Basket Support
Boil Out Temperature Control	Basket Hanger
Legs (non-filter fryers)	Twin Baskets
Casters (filter fryers)	8 GPM Pump
Cords (17 kw)	

EXTERNAL OIL DISCHARGE

External oil discharge -- available on built-in filter batteries of two or more frypots or a frypot spreader -- must specify front or rear connection. Front connection comes with 5ft. washdown hose.	Front \$1,593
	Rear \$1,082

HIGH PRODUCTION HIGH EFFICIENCY RE80 ELECTRIC FRYERS

FRYER ACCESSORIES			
Basket, full size 16-3/4 x 17-1/2 x 5-3/4 Part No. 8030148	\$259	CASTERS - set of four	\$284
Basket, twin size 8-3/4 x 16-3/4 x 6 Part No. 8030304	\$169	Chicken/Fish Tray 16-1/2 x 16-1/2 x 11 8233947	\$351
Basket, twin size, basket lifts 7-5/8 x 15-7/8 x 7-3/8 Part No. 8030306	\$183	Clean-out Rod 27" long Part No. 8030197	\$83
Basket, triplet size 5-5/8 x 16 x 7 Part No. 8030427	\$183	Cover Part No. 1080220	\$306
Basket Hanger 17-3/8 W x 3-1/2 H Part No. 8102794	\$100	Fish Scoop 8-1/8 W x 8-1/2 D with 17-3/8 handle Part No. 8030059	\$96
Basket Support Rack, fine mesh 17-3/8" x 17-5/8" Part No. 8030387	\$150	Fish Skimmer 6" square w/ insulated handle Part No. 8030184	\$87
Brush, L-shaped Tampico 21" L x 2" Diameter Part No. 8030429	\$65	Legs, 6" H, set of four, adjustable (non-filter models)	\$284
Brush, L-shaped Teflon 26-3/4" L x 1" Diameter Part No. 8030278	\$78	Top Connecting Strip Part No. 2305382	\$161

NOTES:

- One cord is provided per 17 kw frypot.
- All 21 kw units must be field wired. No plug or cord provided. Check electrical code for proper supply line sizing.
- Plug is an optional accessory on units shipping with a cord. **EXCEPTION:** Units shipping to Canada with a cord must have a plug as well.
- Optional plug -- (Domestic: NEMA #15-60P) -- Add \$129 for each full or dual split frypot.
- Controller, filter pump and basket lifts are powered by element voltages except 480V fryers.
- All 480V models are provided with separate 120 volt cord and plug for filter pump, controller, and/or basket lifts.
- 480V 3PH option -- Add \$568 per full or dual split frypot
- No plug or cord is provided on single phase fryers.
- Any questions or pricing information other than the above should be referred to **CUSTOMER SERVICE**
-- **TOLL FREE 1-800-221-4583.**

SPREADERS - ADD TO PRICE OF FRYER(S)	
SPREADER CABINET -- 20MC Call Customer Service for availability and placement.	\$1,599

FILTERING ACCESSORIES	
Cone Holder (non-filter models only) (10" Diameter) Part No. 8030072	\$70
Filter Cones (non-filter models only) (10" Diameter- box of 50) Part No. 8030042	\$85
Filter Powder (80, 1oz. Packs) Part No. 8030002	\$100
RE80SUFF* - single under fryer filters; 17 x 33-1/4 Box of 100 sheets Part No. 8030345	\$217
Multi-battered RE80 UFF** Super Cascade Filters; 26 x 34; Box of 100 sheets Part No. 8030303	\$217
Filter Screen (high sediment) 11-1/2 W x 16-3/8 D Part No. 8239077	\$299

* SUFF-Equipped systems are single frypots with built-in filtration only.

** UFF-Equipped systems are multi-battered frypots with built-in filtration only.

EXTERNAL OIL DISCHARGE	
External oil discharge -- available on built-in filter batteries of two or more frypots or a frypot spreader -- must specify front or rear connection. Front connection comes with 5ft. washdown hose.	Front \$1,593 Rear \$1,082

POWER REQUIREMENTS - BASIC DOMESTIC						
MODELS	KW	ELEMENTS/FRYPOT		CONTROLS/FRYPOT	FILTER	BASKET LIFTS/FRYPOT
		VOLTAGE	3 PHASE*			
RE180	17	208v	48 A	1 A	5A	2 A
		240v	41 A	1 A	4A	2 A
		480v	21 A	120v 1 A	120v 8 A	120v 3 A
RE180	21	208v	57 A	1 A	5 A	2 A
		240v	51 A	1 A	4 A	2 A
		480v	26 A	120v 1 A	120v 8 A	120v 3 A

* 3Ph / 3 wire / plus ground wire

DEAN DECATHLON (D) GAS FRYERS

DECATHLON FRYERS WITHOUT FILTRATION, WITH STAINLESS STEEL FRYPOT, DOOR AND CABINET SIDES					
MODEL NUMBER	THERMATRON CONTROLLER	OIL CAPACITY LBS	COOK AREA W" x L" x D"	BTU/HR INPUT	SHIPPING WEIGHT LBS
D150G FULL POT	\$7,349	50	14 x 14 x 3-1/2	120,000	180
D160G FULL POT	\$8,849	75	18 x 18 x 3-3/4	150,000	255

NOTES:

- Piezo Ignitor - Add \$109 per frypot (any controller).
- Split pots not available.

DECATHLON D50 FRYERS WITH FILTRATION, STAINLESS STEEL FRYPOTS, DOORS AND CABINET SIDES					
MODEL NUMBER	THERMATRON CONTROLLER	OIL CAPACITY LBS	COOK AREA W" x L" x D"	BTU/HR INPUT	SHIPPING WEIGHT LBS
SCFD250G FULL POT	\$25,949	(2) 50	(2) 14 x 14 x 3-1/2	(2) 120,000	397
SCFD350G FULL POT	\$34,199	(3) 50	(3) 14 x 14 x 3-1/2	(3) 120,000	610
SCFD450G FULL POT	\$42,449	(4) 50	(4) 14 x 14 x 3-1/2	(4) 120,000	910
SCFD550G FULL POT	\$50,649	(5) 50	(5) 14 x 14 x 3-1/2	(5) 120,000	1,311

NOTES :

- Filter price included.
- Casters included in pricing.
- Piezo ignitor - Add \$109 per frypot (any controller).
- Split pots not available.

DECATHLON D60 FRYERS WITH FILTRATION, STAINLESS STEEL FRYPOTS, DOOR(S) AND CABINET SIDES					
MODEL NUMBER	THERMATRON CONTROLLER	OIL CAPACITY LBS	COOK AREA W" x L" x D"	BTU/HR INPUT	SHIPPING WEIGHT LBS
SCFD260G FULL POT	\$30,299	(2) 75	(2) 18 x 18 x 3-3/4	(2) 150,000	417
SCFD360G FULL POT	\$39,949	(3) 75	(3) 18 x 18 x 3-3/4	(3) 150,000	815
SCFD460G FULL POT	\$49,649	(4) 75	(4) 18 x 18 x 3-3/4	(4) 150,000	1,295

NOTES :

- Filter price included.
- Casters included in pricing.
- Piezo ignitor - Add \$109 per frypot (any controller).
- Split pots not available.

EXTERNAL OIL DISCHARGE	
External oil discharge -- available on built-in filter batteries of two or more frypots or a frypot spreader -- must specify front or rear connection. Front connection comes with 5ft. washdown hose.	Front \$1,593
	Rear \$1,082

STANDARD ACCESSORIES	
Automatic Melt Cycle Boil-out Temperature Control Legs (non-filter fryers) Casters (filter fryers)	Rack-type Basket Support Basket Hanger Twin Baskets

DEAN DECATHLON (D) GAS FRYERS

FILTERING ACCESSORIES			
8GPM Filter Pump Upgrade (systems only)	\$437	Filter Powder (80, 1oz. Packs) Part No. 8030002	\$100
Gloves, black safety Part No. 8030293	\$50	50/60 Fryer, UFF* Equipped; 34 x 22 Box of 100 sheets Part No. 8030289	\$217
Sediment Scoop Part No. 8233696	\$50	80 Fryer, UFF* Equipped; 26 x 34 Box of 100 sheets Part No. 8030303	\$217

* UFF-Equipped systems are multi-battered frypots with built-in filtration only.

SPREADERS - ADD TO PRICE OF FRYERS	
D50G -- 15MC	\$999
D60G -- 20MC	\$1,299

NOTE:

- Call Customer Service for availability and placement.

GAS MANIFOLD REQUIREMENTS		
1" rear gas manifold (per fryer)	WITH FILTER: with shut-off valve	\$82
	without shut-off valve	Standard

DEAN GAS LINE TABLE		
# OF FRYERS	GAS LINE WITHOUT FILTER	GAS LINE WITH FILTER
	Singles	
1	3/4"	N/A
2 - 4	N/A	(1) 1"
5 - 6	N/A	(2) 1"

NOTES:

- If elevation is between 2,000 - 6,000 feet, specify the elevation level. Fryer may not perform at optimum levels above this elevation.
- Any questions or pricing information other than the above should be referred to **CUSTOMER SERVICE -- TOLL FREE 1-800-221-4583.**

DEAN DECATHLON (D) GAS FRYERS (CONTINUED)

FRYER ACCESSORIES			
Basket, full size D50G 12-3/8 x 12-7/8 x 5-1/4 Part No. 8030099	\$244	Cover, frypot without basket lift D60G Part No. 1061479SP	\$304
Basket, full size D60G, D80G 17-1/2 x 16-3/4 x 6 Part No. 8030017	\$259	Cover, frypot without basket lift D80G Part No. 1062470SP	\$308
Basket, triplet size D50G 4-1/2 x 13-1/4 x 6 Part No. 8030357	\$159	Cover, frypot with basket lift D50G Part No. 1062734SP	\$239
Basket, triplet size D60G, D80G 5-5/8 x 15-7/8 x 7-1/4 Part No. 8030427	\$183	Cover, frypot with basket lift D60G Part No. 1062773SP	\$304
Basket, twin size D50G 5-7/8 x 12-5/8 x 6-5/8 Part No. 8030271	\$163	Cover, frypot with basket lift D80G Part No. 1062624SP	\$308
Basket, twin size D60G, D80G 8-3/4 X 16-3/4 x 5-1/4 Part No. 8030304	\$169	Fish scoop 8-1/8 W x 8-1/2 D w/ 17-3/8 handle Part No. 8030059	\$96
Basket, chicken D60G 16-7/8 x 17 x 7-1/2 Part No. 8102384	\$489	Fish skimmer 6" square w/ insulated handle Part No. 8030184	\$87
Basket, chicken D80G 18-7/8 x 19 x 7-1/2 Part No. 8030328	\$517	Flue Deflector - D50G	Call Customer Service to specify model
Basket Hanger D50G, D60G, D80G	Call Customer Service to specify model	Flue Deflector - D60G	Call Customer Service to specify model
Basket Hanger with flue deflector D80G	Call Customer Service to specify model	Flue Deflector - D80G	Call Customer Service to specify model
Basket Support Rack D50G Part No. 8030273	\$91	Legs - 6" H, set of four, adjustable (non-filter models only)	\$284
Basket Support Rack D60G Part No. 8102235	\$167	Quick Disconnect Hose 1" gas line, 36" long Part No. 8061698	\$604
Basket Support Rack D80G Part No. 8030300	\$187	Quick Disconnect Hose 1" gas line, 48" long Part No. 8061699	\$648
Basket Support Rack, fine mesh D50G Part No. 8030277	\$87	Quick Disconnect Hose 3/4" gas line, 36" long Part No. 8061701	\$491
Basket Support Rack, fine mesh D60G Part No. 8030149	\$159	Quick Disconnect Hose - 3/4" gas line, 48" long Part No. 8061700	\$535
Basket Support Rack, fine mesh D80G Part No. 8102122	\$176	Sediment tray - D50G 13-1/2 W x 13-3/4 D Part No. 1064136	\$453
Brush, L-shaped Tampico 21" L x 2" Diameter Part No. 8030429	\$65	Sediment tray - D60G 17-1/4 W x 17-3/4 D Part No. 1062631	\$535
Brush, L-shaped Teflon 26-3/4" L x 1" Diameter Part No. 8030278	\$78	Shelf, Front Work 10" no marine edge D150G, D250G, D350G, D450G, D550G, D160G, D260G, D360G, D460G, D560G, D280G	\$602 per frypot
CASTERS - set of four	\$284	Shelf, Front Work 6" with marine edge D160G, D260G	\$702 per frypot
Chicken/Fish Tray D50G 12-1/2 x 12-1/2 x 11 Part No. 8236895	\$169	Splash Shield D50G Part No. 8233225	\$111
Chicken/Fish Tray D60G 16-1/2 x 16-1/2 x 11 Part No. 8233947	\$351	Top Connecting Strip D50G Part No. 2102681	\$139
Clean-out Rod 27" long Part No. 8030197	\$83	Top Connecting Strip D60G, D80G Part No. 2105086	\$163
Cover, frypot without basket lift D50G 13-1/2 W x 21-3/8 D Part No. 1061637SP	\$239		

DEAN SUPER MARATHON (SM) GAS FRYERS

SUPER MARATHON WITHOUT FILTRATION, WITH STAINLESS STEEL FRYPOT(S), DOOR(S) AND CABINET SIDES					
MODEL NUMBER	MILLIVOLT CONTROLLER	OIL CAPACITY LBS	COOK AREA W" x L" x D"	BTU/HR INPUT	SHIPPING WEIGHT LBS
SM150G FULL POT	\$6,199	(1) 50	(1) 14 x 14 x 3-1/2	120,000	180
SMS020G FULL POT - SPLIT POT	\$11,649	(1) 50 (1) 23	(1) 14 x 14 x 3-1/2 (1) 6-3/4 x 14 x 3-7/8	170,000	295

SUPER MARATHON WITH FILTRATION, STAINLESS STEEL FRYPOTS, DOORS AND CABINET SIDES					
MODEL NUMBER	MILLIVOLT CONTROLLER	OIL CAPACITY LBS	COOK AREA W" x L" x D"	BTU/HR INPUT	SHIPPING WEIGHT LBS
SCFSM250G* FULL POT	\$25,249	(2) 50	(2) 14 x 14 x 3-1/2	(2) 120,000	641

*Standard with Millivolt controller.

NOTES:

- Filter price included.
- Price includes casters.
- Piezo ignitor - Add \$109 per frypot.

FILTERING ACCESSORIES			
8GPM Filter Pump Upgrade (SCFSM250G only)	\$437	Filter Powder (80, 1oz. Packs) Part No. 8030002	\$100
Gloves, black safety Part No. 8030293	\$50	50 Series Fryer, UFF* Equipped; 34 x 22 Box of 100 sheets Part No. 8030289	\$217
Sediment Scoop Part No. 8233696	\$50		

* UFF-Equipped systems are multi-batteried frypots with built-in filtration only.

STANDARD ACCESSORIES	
Legs (non-filter models) Rack-type Basket Support Casters (filter models)	Basket Hanger Twin Baskets

SPREADERS - ADD TO PRICE OF FRYERS	
SMS0G -- 15MC Call Customer Service for availability and placement.	\$999

EXTERNAL OIL DISCHARGE	
External oil discharge -- available on built-in filter batteries of two or more frypots or a frypot spreader -- must specify front or rear connection. Front connection comes with 5ft. washdown hose.	Front \$1,593 Rear \$1,082

SUPER MARATHON GAS LINE TABLE		
	GAS LINE WITHOUT MANIFOLD	GAS LINE WITH MANIFOLD
SM50	3/4"	N/A
SMS020G	(2) 3/4" (standard)	1"
SCFSM250G	(2) 3/4"	1" (standard)

NOTES:

- If elevation is between 2,000 - 6,000 feet, specify the elevation level. Fryer may not perform at optimum levels above this elevation.
- Any questions or pricing information other than the above should be referred to **CUSTOMER SERVICE -- TOLL FREE 1-800-221-4583.**

GAS MANIFOLD REQUIREMENTS (FOR SCFSM250G ONLY)		
1" rear gas manifold (per fryer)	WITH FILTER: with shut-off valve	\$82
	without shut-off valve	Standard

DEAN SUPER MARATHON (SM) GAS FRYERS (CONTINUED)

FRYER ACCESSORIES

Basket, full size SM40G, SM50G 12-3/8 x 12-7/8 x 5-1/4 Part No. 8030099	\$244	Fish scoop 8-1/8 W x 8-1/2 D w/ 17-3/8 handle Part No. 8030059	\$96
Basket, triplet size SM40G, SM50G 4-1/2 x 13-1/4 x 6 Part No. 8030357	\$159	Fish skimmer 6" square w/ insulated handle Part No. 8030184	\$87
Basket, twin size; SM20G, SM40G, SM50G 5-7/8 x 12-5/8 x 6-5/8 Part No. 8030271	\$163	Flue Deflector - SMS0G	Call Customer Service to specify model
Basket Hanger SM40G, SM50G	Call Customer Service to specify model	Legs - 6" H, set of four, adjustable (non-filter models only)	\$284
Basket Support Rack SM40G, SM50G 13-1/2 W x 13-1/4 D Part No. 8030273	\$91	Marine Edge	Call Customer Service to specify model
Basket Support Rack fine mesh SM40G, SM50G Part No. 8030277	\$87	Quick Disconnect Hose 1" gas line, 36" long Part No. 8061698	\$604
Brush, L-shaped Tampico 21" L x 2" Diameter Part No. 8030429	\$65	Quick Disconnect Hose - 1" gas line, 48" long Part No. 8061699	\$648
Brush, L-shaped Teflon 26-3/4" L x 1" Diameter Part No. 8030278	\$78	Quick Disconnect Hose 3/4" gas line, 36" long Part No. 8061701	\$491
CASTERS - set of four	\$284	Quick Disconnect Hose 3/4" gas line, 48" long Part No. 8061700	\$535
Chicken/Fish Tray SMS0G 12-1/2 x 12-1/2 x 11 Part No. 8236895	\$169	Sediment tray - SMS0G 13-1/2 W x 13-3/4 D Part No. 1064136	\$453
Clean-out Rod 26" long Part No. 8030197	\$83	Shelf, Front Work (per frypot) 11" Front Work Shelf Call Customer Service to specify model	\$602
Cover, frypot SM40G, SM50G 13-1/2 W x 21-3/8 D Part No. 1061637SP	\$239	Splash Shield SM40G, SM50G Part No. 8233225	\$111
Cover, frypot SM20G (for SMS020G) 1062505SP \$239		Top Connecting Strip SM40G, SM50G 2102681	\$139



Super Runner Fryers (Gas and Electric)

Outpace the Competition in Performance and Value



SR42 gas fryer shown with optional casters



SR14 electric fryer shown with optional casters



SR62 electric fryer shown with optional casters

- 1. Meet varied production capacity needs.** Model offerings provide 40-75 lb. oil capacity options.
- 2. Can be utilized in operations with gas or electric utilities.** There are four models, three gas and one electric.
- 3. Offer two gas frypot sizes: 14" x 14" and 18" x 18".**
- 4. Have a low warranty failure rate.**
- 5. Have sturdy, long-lasting construction** that includes stainless-steel frypot, door, and backsplash/flue cover.
- 6. Require no electrical hook-up for gas models.**
- 7. Offer an electric model that helps the kitchen stay cool.** Electric elements transfer heat directly to the oil so the kitchen stays cooler.
- 8. Protect against high-heat ignition with reliable high-limit probe.** Gas flow automatically shuts off if temperature exceeds the upper limit.
- 9. Support frying operations with durable accessories** including frypot covers, full size baskets, fine mesh screen, and casters. Triplet baskets are available for the SR62 model's 18" x 18" frypot.

Super Runner Fryers are the front running value fryer of choice.

For more information, contact Customer Service at 1-800-221-4583 or visit www.frymaster.com.

DEAN SUPER RUNNER (SR) GAS FRYERS

SR FRYERS WITH STAINLESS STEEL FRYPOT, FRONT, DOOR AND BACKSPASH/FLUE COVER, ALUMINIZED SIDES

MODEL NUMBER	MILLIVOLT CONTROLLER	OIL CAPACITY LBS	COOK AREA W" x L" x D"	BTU/HR INPUT	SHIPPING WEIGHT LBS
SR142G FULL POT	\$1,799	43	14 x 13-3/4 x 4-1/5	105,000	150
SR162G FULL POT	\$3,699	75	18 x 18 x 3-3/4	150,000	255

NOTES:

- Piezo ignitor - Add \$109 per frypot.
- Split pot not available.

FRYER ACCESSORIES

Basket, full size SR42 12-3/8 x 12-7/8 x 5-1/4 Part No. 8030099	\$244	Brush, L-shaped Tampico 21" L x 2" Diameter Part No. 8030429	\$65
Basket, full size SR62 17-1/2 x 16-3/4 x 6 Part No. 8030017	\$259	Brush, L-shaped Teflon 26-3/4" L x 1" Diameter Part No. 8030278	\$78
Basket, twin size SR42 5-7/8 x 12-5/8 x 6-5/8 Part No. 8030271	\$163	CASTERS - set of four	\$284
Basket, twin size SR62 8-3/4 x 16-3/4 x 5-1/4 Part No. 8030304	\$169	Clean-out Rod 27" long Part No. 8030197	\$83
Basket, triplet size SR62 5-5/8 x 15-7/8 x 7-1/4 Part No. 8030427	\$183	Cover, frypot SR42 13-1/2 W x 21-3/8 D Part No. 1061637	\$239
Basket Hanger SR42 12-1/2 W x 3-3/4 H Part No. 8102793	\$98	Cover, frypot SR62 Part No. 1061479	\$304
Basket Hanger SR62 17 W x 3-1/2 H Part No. 8102794	\$100	Fish Scoop 8-1/8 W x 8-1/2 D w/ 17-3/8 handle Part No. 8030059	\$96
Basket Support Rack SR42 13-1/2" W x 13-1/4" D Part No. 8030273	\$91	Fish Skimmer 6" square w/ insulated handle Part No. 8030184	\$87
Basket Support Rack SR62 17-3/8" x 17-5/8" Part No. 8102235	\$167	Legs - 6" H, set of four	\$284
Basket Support Rack, fine mesh SR42 Part No. 8030277	\$87	Piezo Ignitor (Factory installation only)	\$109
Basket Support Rack, fine mesh SR62 Part No. 8030149	\$159	Top Connecting Strip SR42G Part No. 2102681	\$139
		Top Connecting Strip SR62G Part No. 2105086	\$163

STANDARD ACCESSORIES

Legs Basket Hanger	Twin Baskets Rack-type Basket Support
-----------------------	--

FILTERING ACCESSORIES

Gloves, black safety Part No. 8030293	\$50
Sediment Scoop Part No. 8233696	\$50

NOTES:

- If elevation is between 2,000 - 6,000 feet, specify the elevation level. Fryer may not perform at optimum levels above this elevation.
- Any questions or pricing information other than the above should be referred to **CUSTOMER SERVICE -- TOLL FREE 1-800-221-4583.**

DEAN SUPER RUNNER (SRE) ELECTRIC FRYERS

SRE FRYERS WITH STAINLESS STEEL FRYPOT, FRONT, DOOR AND BACKSPASH/FLUE COVER, ALUMINIZED SIDES					
MODEL NUMBER	MILLIVOLT CONTROLLER	OIL CAPACITY LBS	COOK AREA W" x L" x D"	ELECTRICAL INPUT	SHIPPING WEIGHT LBS
SR114E FULL POT	\$3,349	40	13-3/4 x 13-3/4 x 5-1/4	14 kw	180

FRYER ACCESSORIES			
Basket, full size 12-3/8 x 12-7/8 X 5-1/4 Part No. 8030099	\$244	CASTERS - set of four	\$284
Basket, twin size 5-7/8 x 12-5/8 x 6-5/8 Part No. 8030271	\$163	Clean-out Rod 27" long Part No. 8030197	\$83
Basket Hanger 12-1/2 W x 3-1/2 H Part No. 8102793	\$98	Cover, frypot 14-5/8 W x 19-3/8 D Part No. 8063068	\$224
Basket Support Rack 12-1/2" W x 13-5/8" D Part No. 8030132	\$93	Fish Scoop 8-1/8 W x 8-1/2 D w/ 17-3/8 handle Part No. 8030059	\$96
Brush, L-shaped Tampico 21" L x 2" Diameter Part No. 8030429	\$65	Fish Skimmer 6" square w/ insulated handle Part No. 8030184	\$87
Brush, L-shaped Teflon 26-3/4 L x 1" Diameter Part No. 8030278	\$78	Legs - 6" H, set of four	\$284
		Top Connecting Strip 2302884	\$139

STANDARD ACCESSORIES	
Legs Basket Hanger	Twin Baskets Rack-type Basket Support

FILTERING ACCESSORIES	
Gloves, black safety Part No. 8030293	\$50
Sediment Scoop Part No. 8233696	\$50

NOTES:

- Any questions or pricing information other than the above should be referred to **CUSTOMER SERVICE -- TOLL FREE 1-800-221-4583.**

SPECIALTY PRODUCTS

FRYMASTER SPREADER CABINET, FOOD WARMER AND HOLDING PAN		
AVAILABLE MODELS	PRICE	PRODUCT DESCRIPTION
FQ (gas and electric), OCF30 (gas and electric), H55, HD50G, MJ45, MJ35, RE14, RE14TC, RE17, RE17TC, RE22, RE22TC	\$999	Spreader Cabinet
HD60G	\$1,299	Spreader Cabinet
1814G, MJCF, MJCFE, RE80	\$1,599	Spreader Cabinet
FWH-1	\$1,129	Food Warmer & Holding Pan - Includes heat lamp, cord & plug, and 12" x 20" x 2-1/2" stainless cafeteria style pan & screen.
FWH-1A	\$1,302	Food Warmer & Holding Pan - Includes heat lamp, cord & plug, and 13-1/2" x 17" x 8" scoop-type perforated pan.
Holding Pan	\$352	12" x 20" x 2-1/2" stainless cafeteria style pan & screen
Food Warmer & Holding Pan Combo - RE80	\$1,129	Food warmer & 4" D cafeteria style holding pan with scoop type grated screen

DEAN SPREADER CABINET, FOOD WARMER AND HOLDING PAN		
AVAILABLE MODELS	PRICE	PRODUCT DESCRIPTION
D50G, SM40G, SM50G	\$999	Spreader Cabinet
D60G	\$1,299	Spreader Cabinet
D80G	\$1,599	Spreader Cabinet
FWH-1	\$1,129	Food Warmer & Holding Pan - Includes heat lamp, cord & plug, and 12" x 20" x 2-1/2" stainless cafeteria style pan & screen.
FWH-1A	\$1,302	Food Warmer & Holding Pan - Includes heat lamp, cord & plug, and 13-1/2" x 17" x 8" scoop-type perforated pan.
Holding Pan	\$352	12" x 20" x 2-1/2" stainless cafeteria style pan & screen
Food Warmer & Holding Pan Combo	\$1,129	Food warmer & 4" D cafeteria style holding pan with scoop type grated screen

NOTES:

- Spreader cabinets have a solid flat top or optional 12"W x 20" D cutout.
- Food Warmers/Holding Pans are optional accessories used with Frymaster/Dean spreader cabinets.
- Casters - Add \$284.
- Any questions or pricing information other than the above should be referred to **CUSTOMER SERVICE -- TOLL FREE 1-800-221-4583.**

FRYMASTER SANDWICH HOLDING STATION			
MODEL NUMBER	PRICE	DIMENSIONS W" X D" X H"	PRODUCT DESCRIPTION
SHS18	\$4,605	24 X 18-1/2 X 7-3/4	Specifically designed, heated holding unit that optimizes the hot holding of wrapped foods.
SHS22	\$5,071	24 x 22 x 7-3/4	

FRYMASTER CLEANING SOLUTION CADDY			
MODEL NUMBER	PRICE	DIMENSIONS W" X D" X H"	PRODUCT DESCRIPTION
CSC	\$899		Specifically designed for disposal of boil-out solution

PORTABLE FILTERS

FRYMASTER PORTABLE FILTERS				
MODEL NUMBER	PRICE	CAPACITY LBS	DESCRIPTION	SHIPPING WEIGHT LBS
PF50	\$4,500	50	50-lb oil capacity, reversible pump	120
PF95LP	\$4,949	80	80-lb oil capacity, low profile	140

NOTES:

- 4 GPM filter pump and 5' return hose included.
- Shipped with filter starter kit.
- Available voltage 120V-60 Hz 9 Amp.

FRYMASTER PORTABLE FILTER ACCESSORIES		
DESCRIPTION	PART NUMBER	PRICE
Crumb Tray	8235950	\$190

DEAN PORTABLE FILTERS				
MODEL NUMBER	PRICE	CAPACITY LBS	DESCRIPTION	SHIPPING WEIGHT LBS
MF90/80	\$5,299	80	80-lb oil capacity, reversible pump	120
MF90/80LP*	\$5,299	80	80-lb oil capacity, low profile, reversible pump	147
MF90/110	\$5,399	110	110-lb oil capacity, reversible pump	125

* MF90/80LP low profile filters are also recommended for Frymaster and other fryers.

NOTES:

- 4 GPM filter pump and 5' return hose included.
- Shipped with Frymaster filter starter kit.
- Available voltage 120V-60 Hz 9 Amp.
- Any questions or pricing information other than the above should be referred to **CUSTOMER SERVICE -- TOLL FREE 1-800-221-4583.**

FRYMASTER AND DEAN SHORTENING DISPOSAL UNITS				
MODEL NUMBER	PRICE	CAPACITY LBS	DESCRIPTION	SHIPPING WEIGHT LBS
PSDU50	\$1,749	50	50-lb oil capacity - fits under all Frymaster & Dean fryers except Dean single filtration models	62
PSDU100	\$2,099	100	100-lb oil capacity - fits under all Frymaster & Dean fryers including Dean single filtration models	79

NOTES:

- 9-5/8" drain height with cover open.
- Large 6", high-strength wheels provide easy transporting of oil.
- Any questions or pricing information other than the above should be referred to **CUSTOMER SERVICE -- TOLL FREE 1-800-221-4583.**

SHORTENING DISPOSAL UNIT ACCESSORIES		
DESCRIPTION	PART NUMBER	PRICE
Hose, 24"	8261603	\$143
Hose, 48"	8262173	\$205

FRYMASTER FILTER ACCESSORIES/SUPPLIES

FRYMASTER FILTER ACCESSORIES

ITEM	DESCRIPTION (Inches) (WxDxH)	PART NUMBER	PRICE
Cone Holder	10 Diameter	8030072	\$70
Clean-out rod	26 Long	8030197	\$83
Fish Scoop	8-1/8 W x 8-1/2 D with 17-3/8 handle	8030059	\$96
Filter Cones	10 Diameter -- box of 50	8030042	\$85
Fryer Brush, L-shaped Tampico	21" Long, 2" Diameter	8030429	\$65
Fryer Brush, L-shaped Teflon	26-3/4 Long, 1" Diameter	8030278	\$78
Filter Powder	80, 1 oz. preportioned packs per box	8030002	\$100
Gloves	Black, safety	8030293	\$50
Skimmer	6 square with insulated handle	8030184	\$87

BUILT-IN FILTER	PART NUMBER	PAPER SIZE (inches) (W x D)	PACKAGING	PRICE	SHIPPING WEIGHT
Filter Magic Filters before 5/90	8030003	12-1/2 x 17-3/4	Box of 100 sheets	\$119	3 lbs.
Filter Magic Filters after 5/90	8030170	19-1/2 x 27-1/2	Box of 100 sheets	\$119	4 lbs.
80-lb, MJCF Fryer Filters before 8/90	8030074	17-1/2 x 19-1/4	Box of 100 envelopes	\$363	8 lbs.
80-lb MJCF Fryer Filters after 8/90 and TCF Fryer Filters	8030289	22 x 34	Box of 100 sheets	\$217	8 lbs.
All FootPrint and FootPrint PRO Filters	8030170	19-1/2 x 27-1/2	Box of 100 sheets	\$119	4 lbs.
All Flat Bottom Fryer Filters	8030172	20-1/8 x 25-1/2	Box of 100 sheets	\$272	4 lbs.
RE80 SUFF - Single Under Fryer Filters	8030345	17 x 33-1/4	Box of 100 sheets	\$217	4 lbs.
Multi-batteried RE80 UFF-Super Cascade Filters	8030303	26 x 34	Box of 100 sheets	\$217	4 lbs.
Metal Filter Screen Fits FootPrint PRO Filters*	8102800	11-1/8 x 19-1/4	Fits all PRO filters	\$682	4 lbs.
FilterQuick (gas & electric)	8030445	16-1/2" x 25-1/2"	Box of 100 sheets	\$119	4 lbs.

PORTABLE FILTER	PART NUMBER	PAPER SIZE (inches) (W x D)	PACKAGING	PRICE	SHIPPING WEIGHT
All PF50 Portable Filters	8030170	19-1/2 x 27-1/2	Box of 100 sheets	\$119	4 lbs.
PF95LP Filters	8030284	16-3/8 x 24-3/8	Box of 100 sheets	\$119	8 lbs.

NOTES:

- Frymaster filter paper is specifically designed for each Frymaster filter system. It is specially woven to allow the free flow of oil, while containing the food particles, sediment and other contaminants drawn by the filter powder. For best results, use only genuine Frymaster filter paper. Use of other than Frymaster paper could void warranty.
- Filter powder is a food-grade filtering agent designed for use with Frymaster's built-in and portable filtering systems. It is specially formulated to remove foreign particles, sediment and other contaminants from the oil, leaving it freshened and extending its useful life.
- Any questions or pricing information other than above should be referred to **Customer Service -- Toll Free 1-800-221-4583**.

*Must be ordered at time of manufacturing of FootPrint PRO filter system.

DEAN FILTER ACCESSORIES/SUPPLIES

DEAN FILTER ACCESSORIES

ITEM	DESCRIPTION (Inches) (WxDxH)	PART #	PRICE
8 GPM Filter Pump (systems only)	Upgrade to 8GPM filter pump (systems only)	Call Customer Service	\$437
5 ft. Hose With Nozzle	For washdown use (built-in filter systems)	1062568	\$572
External Oil Discharge	Front connection comes with 5 ft. washdown hose. See product pages for availability.	N/A	Front \$1,593
			Rear \$1,082
Filter Powder	80, 1 oz. preportioned applications	8030002	\$100
Fryer Brush, L-shaped Tampico	21" Long, 2" Diameter	8030429	\$65
Fryer Brush, L-shaped Teflon	26-3/4" Long, 1" Diameter	8030278	\$78
Gloves	Black, safety	8030293	\$50
Sediment Scoop	Large	8233696	\$50

BUILT-IN FILTER	PART NUMBER	PAPER SIZE (inches) (W x D)	PACKAGING	PRICE	SHIPPING WEIGHT
50 Series Fryers, SUFF-Equipped* before 2001	8030345	17 x 33-1/4	Box of 100 sheets	\$217	4 lbs.
50 Series Fryers, SUFF-Equipped* 2001 & older	8030317	8-1/4 x 25-3/4	Box of 100 sheets	\$119	3 lbs.
60 Series Fryers, SUFF-Equipped*	8030345	17 x 33-1/4	Box of 100 sheets	\$217	4 lbs.
80/18UE Series Fryers, SUFF-Equipped*	8030345	17 x 33-1/4	Box of 100 sheets	\$217	4 lbs.
50 Series Fryers, UFF-Equipped**	8030289	22 x 34	Box of 100 sheets	\$217	8 lbs.
60 Series Fryers, UFF-Equipped**	8030289	22 x 34	Box of 100 sheets	\$217	8 lbs.
80/100/18UE Series Fryers, UFF Equipped**	8030303	26 x 34	Box of 100 sheets	\$217	4 lbs.

PORTABLE FILTER	PART NUMBER	PAPER SIZE (inches) (W x D)	PACKAGING	PRICE	SHIPPING WEIGHT
MF90/80 and 90/110	8030285	16-3/8 x 18-3/8	Box of 100 sheets	\$119	10 lbs.
MF90-80LP (Low Profile)	8030284	16-3/8 x 22	Box of 100 sheets	\$119	8 lbs.

NOTES:

• Any questions or pricing information other than above should be referred to **Customer Service -- Toll Free 1-800-221-4583**.

*SUFF-Equipped systems are single frypots with built-in filtration only.

**UFF-Equipped systems are multi-batteredied frypots with built-in filtration only.



Gas Cookers

Endless Pastabilites For Your Operation!

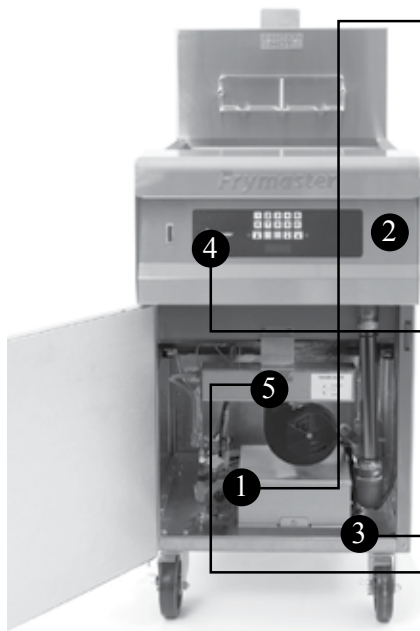

1. **The electrical components are separated** from the heating system and shielded from moisture.
2. **New front panel design** keeps top cap cool and water out.
3. **Sealed bottom** protects against vented steam and moisture reentering the cabinet and damaging components.
4. **Programmable timer controller** times the cook operation and signals audibly when cook is complete.
5. **High-efficiency infrared burners** and the electronic ignition module have outstanding reliability and performance. Water heat-ups go from 60° F to boiling in 24 minutes, 50% faster than previous models.

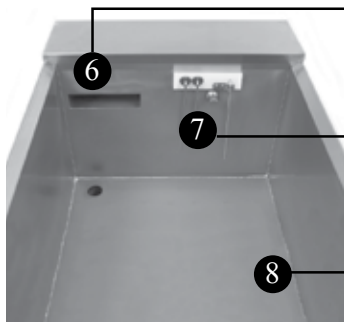

6. **Overflow drain** is the largest in the industry and protects against boil-over.
7. **Auto-fill/starch skimmer** keeps the water level at the correct height and removes excess starch residue from the water's surface.
8. **Open cookpot** is easy to clean.

For more information, contact customer service at 1-800-221-4583.

PASTA COOKERS

GAS PASTA COOKERS - STAINLESS STEEL COOKPOT, DOOR & CABINET					
MODEL NUMBER	PRICE	CAPACITY GAL	COOK AREA W" x L" x D"	BTU/HR INPUT	SHIPPING WEIGHT LBS
GPC* GAS PASTA COOKER	\$13,999	15	18 X 24 X 6-3/4	80,000	331
GPCRB GPC WITH RINSE TANK & BASKET LIFTS	\$20,799	15	18 X 24 X 6-3/4	80,000	468

* Swing away hot/cold faucet not available on GPC.

NOTES:

- If elevation is between 5,000 - 10,000 feet, specify the elevation level. Unit may not perform at optimum levels above this elevation.
- Casters included in pricing on GPCRB.
- See page 68 for optional accessories.

STANDARD ACCESSORIES	
Auto-fill/skim Legs (GPC) Bulk Pasta Basket	Casters (GPCRB) 12-Cup Portion Cup Rack with 24 Portion Cups Option of Three Round Pasta Baskets

ELECTRIC PASTA COOKERS - STAINLESS STEEL COOKPOT, DOOR & CABINET					
MODEL NUMBER	PRICE	CAPACITY GAL	COOK AREA W" x L" x D"	ELECTRICAL INPUT	SHIPPING WEIGHT LBS
8C ELECTRIC PASTA COOKER	\$11,649	8-3/4	16 x 18-3/4 x 6-1/4	8 kw	192
8SMS 8C WITH RINSE TANK & BASKET LIFTS	\$18,749	8-3/4	16 x 18-3/4 x 6-1/4	8 kw	299

NOTES:

- Casters included in pricing on 8SMS.
- See page 68 for optional accessories.
- Any questions or pricing information other than the above should be referred to **CUSTOMER SERVICE -- TOLL FREE 1-800-221-4583.**

*Available in 3 phase only.

STANDARD ACCESSORIES	
Auto-fill/skim Legs	Bulk Pasta Basket 9-Cup Portion Cup Rack with 18 Portion Cups

GAS FRYER ACCESSORIES



Full Size Basket



Triplet Basket



Twin Baskets



Basket Hanger



Basket Hanger
Over the Flue



Basket Support Racks



Basket Support Screens



Basket Support Screen
with handle

DESCRIPTION	SIZE (Inches) (WxDxH)	PART NO.	APPLICABLE MODELS	PRICE
Basket, full size	17-1/2 x 16-3/4 x 6	8030017	MJCF, HD60G	\$259
Basket, full size (cannot be used with basket lifts)	12-3/8 x 12-7/8 X 5-1/4	8030099	H55, MJ45, GF40, OCF30, HD50G,	\$244
Basket, full size (cannot be used with basket lifts)	11-5/8 x 14 x 4-5/8	8030015	MJ35, GF14	\$244
Basket, full size	17-1/2 x 12-7/8 x 6-1/8	8030435	1814	\$252
Basket, full size		8030148	LHD65	\$259
Basket, triplet size	4-1/2 x 13-1/4 x 6	8030357	H55, MJ45, GF40, HD50G	\$159
Basket, triplet size	5-3/4 x 17-1/8 x 6-1/8	8030023	MJCF	\$195
Basket, triplet size	4-1/4 x 13-1/4 x 5-1/2	8030438	OCF30	\$159
Basket, triplet size	5-5/8 x 15-7/8 x 7-1/4	8030427	HD60G, LHD65	\$183
Basket, twin size	5-7/8 x 12-5/8 x 6-5/8	8030271	H55, MJ45, MJ35, GF40, GF14, OCF30, 1814, HD50G, ESG35T	\$163
Basket, twin size	8-3/4 x 16-3/4 x 6	8030024	MJCF	\$252
Basket, twin size	8-3/4 x 16-3/4 x 5-1/4	8030304	HD60G, LHD65	\$169
Basket, chicken	17-3/4 x 12-1/4 x 6	8030436	1814	\$461
Basket, chicken	16-7/8 x 17 x 7-1/2	8102384	HD60G	\$489
Basket, dual	8 x 12-5/8 x 7	8030437	1814	\$166
Basket, quad	4-1/2 x 13-1/4 x 6	8030357	1814	\$159
Basket hanger	12-1/2 W x 3-1/2 H	8102793	H55, MJ45, MJ35, GF40, GF14	\$98
Basket hanger, flue mounted		2105777	MJ45, MJ35	\$78
Basket hanger	17-3/8 W x 3-1/2 H	8102794	MJCF, RE80	\$100
Basket hanger	15-3/8 W x 5 H	2308165	OCF30 single frypot	\$89
Basket hanger	31 W x 5 H	2307495	FQ & OCF30 two frypot fryer/four frypot fryer (2)	\$179
Basket hanger	46-1/2 W x 5 H	2307497	FQ & OCF30 three frypot fryer	\$268
Basket hanger		8102793	ESG35T	\$98
Basket hanger - over the flue	20 W x 8-1/2 H	8237770	11814 single frypot	\$89
Basket hanger - over the flue	39-3/4 W x 8-1/2 H	8237771	21814 two frypot fryer	\$179
Basket hanger - over the flue	55-1/4 W x 8-1/2 H	8237772	11814/HD50G/11814	\$268
Basket hanger - over the flue		2101595	HD50G (singles) Call Customer Service for batteries	\$91
Basket hanger - over the flue		2102737	HD60G (singles) Call Customer Service for batteries	\$91
Basket hanger with flue deflector		8235859	LHD65	\$107
Basket support rack type-- full pot	12-1/2 W x 13-3/4 D	8030132	H55, MJ45, GF40	\$93
Basket support rack type-- full pot	11-1/2 W x 14-5/8 D	8030032	MJ35, GF14	\$87
Basket support rack type-- full pot		8030137	MJCF	\$102
Basket support rack type-- full pot	11-7/8 W x 13-1/2 D	8030375	OCF30	\$93
Basket support rack type-- split pot	5-7/8 W x 13-1/2 D	8030372	OCF30	\$83
Basket support rack type-- split pot	5-7/8 W x 14 D	8030133	H55, MJ45	\$83
Basket support rack type -- full pot	13-5/8 W x 18 D	8030380	1814	\$111

NOTE:

• Any questions or pricing information other than above should be referred to **Customer Service -- Toll Free 1-800-221-4583.**

GAS FRYER ACCESSORIES



L-shaped Brush, Tampico



L-shaped Brush, Teflon



Casters

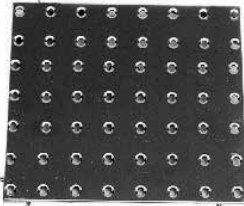

Chicken/Fish Plate

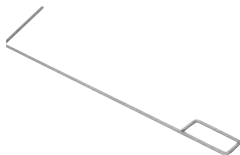

Clean-out Rod



Covers



Crumb Scoop

DESCRIPTION	SIZE (Inches) (WxDxH)	PART NO.	APPLICABLE MODELS	PRICE
Basket support rack type	17-5/8 W x 17-3/8 D	8102235	LHD65, HD60G	\$167
Basket support rack type	13-1/2 W x 13-1/4 D	8030273	HD50G	\$91
Basket support rack type	13-1/2 W x 11-1/4 D	8030442	ESG35T	\$87
Basket support rack, fine mesh		8030277	HD50G	\$87
Basket support rack, fine mesh		8030149	LHD65, HD60G	\$159
Basket support screen type with handle – full pot only.	12-1/2 W x 13-3/4 D	8030136	H55, MJ45, GF40	\$129
Basket support screen type – full pot only.	11-1/2 W x 14-5/8 D	8030037	MJ35, GF14	\$115
Basket support screen type with handle – full pot only.	17-1/2 W x 18-1/2 D	8030138	MJCF	\$135
L-Basket Support Rack		8103066	LHD65	\$201
Brush L-shaped, Tampico	21 Long, 2 Diameter	8030429	All models	\$65
Brush L-shaped, Teflon	26-3/4 Long, 1 Diameter	8030278	All models	\$78
Bulk oil kit			OCF30	Call Customer Service
Casters – set of four		Call Customer Service to specify fryer models	H55, MJ45, MJ35, GF40, GF14, MJCF	\$284
Chicken/Fish Plate – full pot (not available for split pot)	11-3/4 W x 13-1/2 D	8230619	H55, MJ45, GF40	\$344
Chicken/Fish Plate – full pot	11 W x 14 D	8233048	MJ35, GF14	\$300
Chicken/Fish Plate – full pot	17 W x 18 D	8230368	MJCF	\$419
Chicken/Fish Plate – full pot	12 W x 13-3/8 D	8238066	FQ, OCF30	\$337
Chicken/Fish Plate – full pot	18 W x 13-5/8 D	2208966	1814	\$344
Chicken/Fish Tray – full pot	13-5/8 W x 13-1/2 D	2208963	HD50G	\$337
Chicken/Fish Tray -- full pot	16-1/2 x 16-1/2 x 11	8233947	HD60G,	\$351
Clean-out rod	27 Long	8030197	All models (except FQ)	\$83
Clean-out rod	27 Long	8030388	FQ	\$83
Cover -- stainless steel	20-3/8 W x 28 D	8061343	MJCF	\$248
Cover – stainless steel – full pot	15-1/8 W x 20-1/4 D 14-5/8 W x 20-1/4 D	8065518 8063068 with basket lifts	H55, MJ45, MJ35, GF40, GF14	\$220 \$224
Cover – stainless steel – split pot	7-1/2 W x 20-3/8 D	8063232	H55-2, MJ45-2	\$131
Cover -- stainless steel -- full pot	14-5/8 W x 21 D	1068930	FQ, OCF30	\$220
Cover - stainless steel -- split pot	7-1/4 W x 21 D	1068931	FQ, OCF30	\$131
Cover - stainless steel -- full pot	21-3/8 W x 19-1/2 D	1081872	11814	\$239
Cover - stainless steel - full pot		1061637	HD50G, ESG35T	\$239
Cover - stainless steel w/o basket lifts		1061479SP	HD60G	\$304
Cover - stainless steel w/basket lifts		1062734SP	HD50G	\$239
Cover - stainless steel w/basket lifts		1062773SP	HD60G	\$304
Crumb Scoop Cold Zone -- full pot	1-3/4 W x 6-1/2 D x 22-3/4 Long	8233660	H55, MJ45, MJ35, MJCF	\$89
Crumb Scoop Cold Zone -- split pot	1-1/4 W x 6-1/2 D x 22-3/4 Long	8233938	H55-2, MJ45-2	\$89

NOTE:

• Any questions or pricing information other than above should be referred to **Customer Service -- Toll Free 1-800-221-4583.**

GAS FRYER ACCESSORIES



*Fish Scoop, left
Fish Skimmer, right*



Flue Deflector



Jug in Box (JIB) Holder



Legs



Quick Disconnect



Sediment Tray - Full Pot



*Sediment Tray -
MJCF Gas Fryer*

DESCRIPTION	SIZE (Inches) (WxDxH)	PART NO.	APPLICABLE MODELS	PRICE
Elevated top-off container kit			FQ	\$748
Fish plate	12 x 13-3/8 x 3/8	8238066	FQ, OCF	\$337
Fish scoop	8-1/8 W x 8-1/2 D with 17-3/8 handle	8030059	All models	\$96
Fish skimmer	6 square with 13-5/8 insulated handle	8030184	All models	\$87
Fish skimmer	6 square with 13-5/8 insulated handle, no hooks	8030446	FQ	\$87
Flue deflector	12-1/2 W x 6 H	9103557	H55, MJ45, MJ35, GF40, GF14	\$100
Flue deflector		9103185	MJCF	\$105
Flue deflector		8235801	LHD65	\$113
Foam Deck Basket Banger			1814, H55, HD50G, HD60G	\$190/frypot
Gloves, black safety		8030293	All models	\$50
Jug in Box (JIB) Holder -- stainless steel (not NSF approved)	10-1/2 x 10-1/2 x 8-1/2	8242298	OCF30ATO	\$282
Legs -- set of four -- nickel	6 H	8103169	MJ45, MJ35, MJCF, GF40, GF14,	\$213
Legs -- set of four -- stainless steel	6 H	8101205	MJ45, MJ35, MJCF	\$284
Legs -- set of four -- stainless steel	8-1/2 H	Call Customer Service to specify fryer models	H55	\$284
Quick disconnect with 1" gas line -- systems only	36 Long	8061698	H55, MJ45, MJ35, MJCF, 1814, OCF30, LHD65	\$604
Quick disconnect with 1" gas line -- systems only	48 Long	8061699	H55, MJ45, MJ35, MJCF, 1814, OCF30, LHD65	\$648
Quick disconnect with 3/4" gas line -- single units	36 Long	8061701	H55, MJ45, MJ35, GF40, GF14, 1814, OCF30G, LHD65	\$491
Quick disconnect with 3/4" gas line -- single units	48 Long	8061700	H55, MJ45, MJ35, GF40, GF14, 1814, OCF30G, LHD65	\$535
Sediment tray -- full pot	12-1/2 x 14-1/8 x 6-1/2	8030103	H55, MJ45, GF40	\$441
Sediment tray -- full pot	11-1/8 x 14-1/2 x 3-3/8	8030188	MJ35, GF14	\$363
Sediment tray -- full pot		8030187	MJCF	\$465
Sediment tray -- full pot	11-7/8 x 15-1/4 x 6-1/2	8030382	OCF30	\$441
Sediment tray -- split pot left	5-3/4 x 14 x 6-1/2	8030107 (L)	H55-2, MJ45-2	\$337
Sediment tray -- split pot right	5-3/4 x 14 x 6-1/2	8030108 (R)	H55-2, MJ45-2	\$337
Sediment tray	13-1/2 W x 13-3/4 D	1064136	HD50G	\$453
Sediment tray	17-1/4 W x 17-3/4 D	1062631	HD60G	\$535
Sediment tray	13-1/2 W x 13-3/4 D	1064136	HD50G	\$453
Sediment tray	17-1/4 W x 17-3/4 D	1062631	HD60G	\$535
Sediment tray	17-3/4 W x 13-5/8 D	1086187	1814E	\$494

GAS FRYER ACCESSORIES



Splash Shield



Top Connecting Strip

DESCRIPTION	SIZE (Inches) (WxDxH)	PART NO.	APPLICABLE MODELS	PRICE
Splash shield	20 D x 6-1/4 H	8236559	H55, MJ45, MJ35	\$113
Splash shield	30-3/8 D x 13-1/8 H	8235978	MJCF	\$121
Splash shield	21-3/8 D x 7-7/8 H	8237619	11814	\$246
Splash shield, side	19-1/2 D x 11-3/4 H	8238224	FQ, OCF30	\$113
Splash shield, bottom		Call Customer Service to specify fryer models & pricing	FQ	
Splash shield		8233225	HD50G	\$111
Splash shield		8235744	HD60G	\$129
Splash shield		8235789	LHD65	\$189
Thermostat knob guard		9100557	MJ45, MJ35, MJCF	\$72
Top connecting strip	2-1/2 W x 20-1/2 D	2109291	H55, MJ45, MJ35	\$139
Top connecting strip	2 W x 29-1/4 D	9102662	MJCF	\$163
Top connecting strip		2102681	1814G, HD50	\$139
Top connecting strip		2105086	HD60G	\$163
Top connecting strip		8235810	OCF30G	\$139
Top connecting strip		9102285	GF14	\$139
Top connecting strip		9104617	GF40	\$139
Front work shelf 10" without marine edge-- must be requested with fryer order		Call Customer Service to specify fryer models	HD150G, HD250G, HD350G, HD450G, HD550G, HD160G, HD260G, HD360G, HD460G, HD560G	\$602 per frypot
Front work shelf 6" with marine edge-- must be requested with fryer order			HD160G, HD260G	\$702 per frypot

ELECTRIC FRYER ACCESSORIES



Full Size Basket



Triplet Basket



Twin Baskets



Basket Hanger

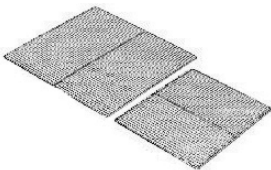

Basket Support Screens



Basket Support Screen with handle



L-Shaped Brush, Tampico



L-shaped Brush, Teflon



Casters

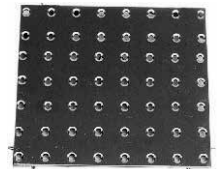

Chicken/Fish Plate

DESCRIPTION	SIZE (Inches) (WxDxH)	PART NUMBER	APPLICABLE MODELS	PRICE
Basket, full size (cannot be used with basket lifts)	12-3/8 x 12-7/8 x 5-1/4	8030099	RE14, RE17, RE22, RE14TC, RE17TC, RE22TC, OCF30, SR14E	\$244
Basket, full size	16-3/4 x 17-1/2 x 5-3/4	8030148	RE80	\$259
Basket, full size	17-1/2 x 12-7/8 x 6-1/8	8030435	1814	\$252
Basket, triplet size	5-5/8 x 15-7/8 x 6-1/4	8030427	RE80	\$183
Basket, triplet size	4-1/2 x 13-1/4 x 6	8030357	RE14, RE17, RE22	\$159
Basket, triplet size	4-1/4 x 13-1/4 x 5-1/2	8030438	OCF30	\$159
Basket, twin size	5-7/8 x 12-5/8 x 6-5/8	8030271	RE14, RE17, RE22, RE14TC, RE17TC, RE22TC, OCF30, SR14E, 1814E	\$163
Basket, twin size	8-3/4 x 16-3/4 x 6	8030304	RE80	\$169
Basket, twin size	7-5/8 x 15-7/8 x 7-3/8	8030306	RE80 w/BL, FPC 28 kw	\$183
Basket, chicken	17-3/4 x 12-3/4 x 11	8030441	1814	\$461
Basket, dual	8 x 12-5/8 x 7	8030437	1814	\$166
Basket, quad	4-1/2 x 13-1/4 x 6	8030357	1814	\$159
Basket hanger, wire	12-1/2 W x 3-1/2 H	8102793	RE14, RE17, RE22, RE14TC, RE17TC, RE22TC, SR14E	\$98
Basket hanger	15-3/8 W x 5 H	2308165	OCF30 single frypot	\$89
Basket hanger	31 W x 5 H	2307495	FQ & OCF30 two frypots / four frypots (2)	\$179
Basket hanger	46-1/2 W x 5 H	2307497	FQ & OCF30 three frypots	\$268
Basket hanger	17-3/8 W x 3-1/2 H	8102794	RE80	\$100
Basket hanger - over the flue	19-7/8 W x 5-1/4 H	2304318	11814E single frypot	\$89
Basket hanger - over the flue	39-3/4 W x 5-1/4 H	2308464	21814E two frypot fryer	\$179
Basket hanger - over the flue	55-7/8 W x 5-1/4 H	2308319	11814E/ RE17/11814E	\$268
Basket support screen type with handle -- full pot (not available for split pot).	12-1/2 W x 13-3/4 D	8030136	RE14, RE17, RE22, RE14TC, RE17TC, RE22TC, OCF30 Fryers	\$129
Brush L-shaped, Tampico	21 Long, 2 Diameter	8030429	All models	\$65
Brush L-shaped, Teflon	26-3/4 Long, 1 Diameter	8030278	All models	\$78
Bulk oil kit			OCF30	Call Customer Service
Casters -- set of four		Call Customer Service to specify fryer models	RE14, RE17, RE22, RE14TC, RE17TC, RE22TC, RE80, 11814E	\$284
Chicken/Fish Plate -- full pot (not available for split pot)	12 W x 13-3/8 D	8238065	FQ, OCF30	\$337
Chicken/Fish Plate -- full pot	17 W x 13-1/2 D	2208962	1814E	\$344
Chicken/Fish Plate -- full pot (not available for split pot)	13-5/8 W x 14-1/4 D	2208964	RE14, RE17, RE22, RE14TC, RE17TC, RE22TC	\$344
Chicken/fish tray	16-1/2 x 16-1/2 x 11	8233947	RE80	\$351

NOTE:

• Any questions or pricing information other than above should be referred to **Customer Service -- Toll Free 1-800-221-4583.**

ELECTRIC FRYER ACCESSORIES

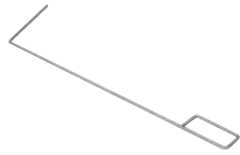

Clean-out Rod



Covers



Fish Scoop, left
Fish Skimmer, right



Jug in Box (JIB) Holder



Legs



Rack Type Basket Support



Sediment Tray



Splash Shield



Top Connecting Strip

DESCRIPTION	SIZE (Inches) (WxDx H)	PART NUMBER	APPLICABLE MODELS	PRICE
Clean-out rod	27 Long	8030197	All models (except FQ)	\$83
Clean-out rod	27 Long	8030388	FQ	\$83
Cover	20 x 22-1/4 x 1-1/2 includes handle	1080220SP	RE80	\$306
Cover -- stainless steel -- full pot	14-5/8 W x 19-3/8 D	8063068	RE14, RE17, RE22, RE14TC, RE17TC, RE22TC, SR14E	\$224
Cover -- stainless steel -- split pot	9 W x 19-1/2 D	8063071	RE14-2, RE17-2, RE22-2, RE14-2TC, RE17-2TC, RE22-2TC	\$131
Cover -- stainless steel -- full pot	14-3/8 W x 19-1/2 D	1068325	OCF30	\$220
Cover -- stainless steel -- split pot	7-1/2 W x 19-3/8 D	1068329	OCF30	\$131
Cover -- stainless steel -- full pot	19 W x 19-3/8 D	1069620	1814E	\$239
Elevated top-off container kit			FQ	\$748
Fish Plate	13 x 13-1/2 x 4-1/2	8238065	FQ, OCF	\$337
Fish scoop	8-1/8 W x 8-1/2 D with 17-3/8 handle	8030059	All models	\$96
Fish skimmer	6 square with 13-5/8 insulated handle	8030184	All models	\$87
Gloves, black safety		8030293	All models	\$50
Jug in Box (JIB) holder -- stainless steel (not NSF approved)	10-1/2 x 10-1/2 x 8-1/2	8242298	OCF30ATO	\$282
Legs -- set of four -- stainless steel	8-1/2 H	Call Customer Service to specify fryer models	RE14, RE17, RE22, RE14TC, RE17TC, RE22TC, RE80, 11814E	\$284
Rack type basket support -- full pot	12-1/2 W x 13-3/4 D	8030132	RE14, RE17, RE22, RE14TC, RE17TC, RE22TC, OCF30 Fryers	\$93
Rack type basket support -- split pot	5-3/4 W x 13-1/2 D	8030106	RE14-2, RE17-2, RE22-2, RE14-2TC, RE17-2TC, RE22-2TC, OCF Fryers	\$83
Rack type basket support -- full pot	13-5/8 W x 18 D	8030380	1814E	\$111
Rack type basket support, fine mesh	17-3/8 W x 17-5/8 D	8030387	RE80	\$150
Sediment tray -- full pot	10-1/2 x 11-5/8 x 4	8030358	RE14, RE17, RE22, RE14TC, RE17TC, RE22TC	\$441
Sediment tray -- split pot left	4-5/8 x 13-7/8 x 4	8030360 (L)	RE14-2, RE17-2, RE22-2, RE14-2TC, RE17-2TC, RE22-2TC	\$337
Sediment tray --split pot right	4-5/8 x 13-7/8 x 4	8030359 (R)		\$337
Sediment tray	17-3/4 W x 13-5/8 D	1086187	11814E	\$494
Splash shield	20 D x 6-1/8 H	8236559	RE14, RE17, RE22, RE14TC, RE17TC, RE22TC	\$113
Splash shield	20-5/8 D x 6 H	8238155	1814E	\$246
Splash shield, side	19-1/2 D x 11-3/4 H	8238224	FQ, OCF30	\$113
Splash shield, bottom		Call Customer Service to specify fryer models & pricing	FQ	
Top connecting strip	1-7/8 W x 21 D	8235810	RE14, RE17, RE22, RE14TC, RE17TC, RE22TC	\$139
Top connecting strip	2 W x 23-3/4 D	2305382	RE80	\$161
Top connecting strip		2308819	FQ, 11814E	\$139

NOTE:

• Any questions or pricing information other than above should be referred to **Customer Service -- Toll Free 1-800-221-4583.**

DEAN GAS FRYER ACCESSORIES



Full Size Basket



Triplet Basket



Twin Baskets

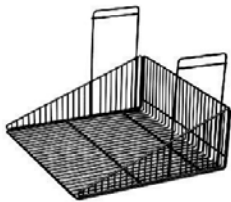

Chicken Basket



Basket Hanger



Basket Support Rack



Basket Support Rack, Fine Mesh

DESCRIPTION	SIZE (Inches) (WxDxH)	PART NO.	APPLICABLE MODELS	PRICE
Basket, full size	12-3/8 x 12-7/8 x 5-1/4	8030099	SM50G, D50G, D50GDD, SR42	\$244
Basket, full size	17-1/2 x 16-3/4 x 6	8030017	D60G, SR62	\$259
Basket, triplet size	4-1/2 x 13-1/4 x 6	8030357	SM50G, D50G	\$159
Basket, triplet size	5-5/8 x 15-7/8 x 7-1/4	8030427	D60G, SR62	\$183
Basket, twin size	5-7/8 x 12-5/8 x 6-5/8	8030271	SM50G, D50G, SR42	\$163
Basket, twin size	8-3/4 x 16-3/4 x 5-1/4	8030304	D60G, D80G, SR62	\$169
Basket, chicken	16-7/8 x 17 x 7-1/2	8102384	D60G, SR62	\$489
Basket hanger		2101595	SM50G, D50G (single models) Call Customer Service for D model batteries.	\$91
Basket hanger		2102737	D60G (single models) Call Customer Service for D model batteries.	\$91
Basket hanger		2103911	SM5020	\$96
Basket hanger, wire	12-1/2 W x 3-3/4 H	8102793	SR42	\$98
Basket hanger, wire	17 W x 3-1/2 H	8102794	SR62	\$100
Basket hanger, with flue deflector		8235794	SM5020	\$98
Basket support rack	13-1/2 W x 13-1/4 D	8030273	SM50G, D50G, SR42	\$91
Basket support rack		8102235	D60G, SR62	\$167
Basket support rack, fine mesh		8030277	SM50G, D50G, SR42	\$87
Basket support rack, fine mesh		8030149	D60G, SR62	\$159

NOTE: • Any questions or pricing information other than above should be referred to **Customer Service** -- Toll Free 1-800-221-4583.

DEAN GAS FRYER ACCESSORIES



L-Shaped Brush, Tampico



L-shaped Brush, Teflon



Casters

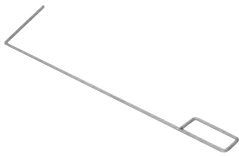

Clean-out Rod



Cover



Quick Disconnect



Chicken/Fish Tray

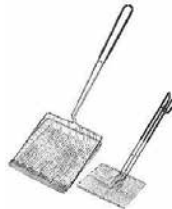

Fish Scoop, left
Fish Skimmer, right



Flue Deflector



Legs

DESCRIPTION	SIZE (Inches) (WxDxH)	PART NO.	APPLICABLE MODELS	PRICE
Brush, L-shaped Tampico	21 Long, 2 Diameter	8030429	All models	\$65
Brush, L-shaped Teflon	26-3/4 Long, 1 Diameter	8030278	All models	\$78
Casters, set of 4		Call Customer Service to specify fryer models	All models	\$284/set
Chicken/Fish Tray	12-1/2 x 12-1/2 x 11	8236895	SM50G, D50G	\$169
Chicken/Fish Tray	16-1/2 x 16-1/2 x 11	8233947	D60G	\$351
Clean-out rod	27 Long	8030197	All models	\$83
Cover, frypot w/o basket lift	13-1/2 W x 21-3/8 D	1061637SP	SM50G, D50G, SR42	\$239
Cover, frypot w/o basket lift		1061479SP	D60G, SR62	\$304
Cover, frypot with basket lift		1062734SP	D50G	\$239
Cover, frypot with basket lift		1062773SP	D60G	\$304
Fish scoop		8030059	All models	\$96
Fish skimmer	6 square with 13-5/8 insulated handle	8030184	All models	\$87
Flue deflector	15-3/8 W x 3 H	2003651	SM50G, D50G	\$102
Flue deflector	18-3/8 W x 3 H	2003649	D60G	\$135
Gloves, black safety		8030293	All models	\$50
Legs, stainless steel set of 4	6 H		Call Customer Service to specify fryer models	\$284
Quick disconnect with gas line 1"x36"	36 Long	8061698		\$604
Quick disconnect with gas line 1"x48"	48 Long	8061699		\$648
Quick disconnect with gas line 3/4"x36"	36 Long	8061701		\$491
Quick disconnect with gas line 3/4"x48"	48 Long	8061700		\$535

NOTE:

• Any questions or pricing information other than above should be referred to **Customer Service -- Toll Free 1-800-221-4583.**

DEAN GAS FRYER ACCESSORIES

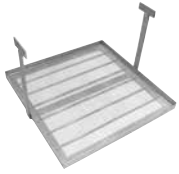

Sediment Tray



Splash Shield



Switch Guard



Top Connecting Strip

DESCRIPTION	SIZE (Inches) (WxDxH)	PART NO.	APPLICABLE MODELS	PRICE
Sediment tray	13-1/2 W x 13-3/4 D	1064136	SM50, D50G	\$453
Sediment tray	17-1/4 W x 17-3/4 D	1062631	SM60G, D60G, SR62	\$535
Splash shield		8233225	SM50G, D40G, D50G	\$111
Splash shield		8235744	SM60G, SM80G, D60G	\$129
Top connecting strip		2102681	SM50G, D50G, SR42G	\$139
Top connecting strip		2105086	D60G	\$163
Switch guard		2102786		\$37
Front work shelf 10" without marine edge-- must be requested with fryer order		Call Customer Service to specify fryer models	D150G, D250G, D350G, D450G, D550G, D160G, D260G, D360G, D460G, D560G	\$602 per frypot
Front work shelf 6" with marine edge-- must be requested with fryer order			D160, D260	\$702 per frypot

PASTA ACCESSORIES



Casters

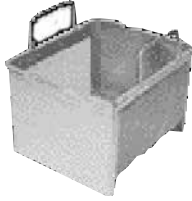

Bulk Pasta Basket

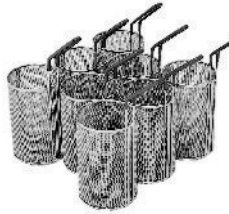

Round Baskets



Quick Disconnect



Portion Cup Rack Shown with Portion Cups

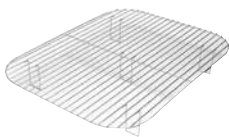

Support Rack



Rinse Tank Screen

DESCRIPTION	SIZE (Inches) (WxDxH)	PART NUMBER	APPLICABLE MODELS	PRICE
Casters - set of four		Call Customer Service	GPCRB, GPC, 8SMS, 8C	\$284
Pasta, bulk basket	13-1/2 x 16-1/2 x 9-3/4	8237384	GPCRB, GPC	\$400
Pasta, bulk basket	12 x 14-3/4 x 9-3/4	8236290	8SMS, 8C	\$342
Pasta round basket (capacity - 12 per gas units and 17 kw electric units ; 8 per 8 kw electric units)	5-1/2 Diameter x 8-1/2 H	8030238	GPCRB, GPC, 8SMS, 8C	\$187
Pasta, quick disconnect kit with hot and cold water lines		8065848SP	GPCRB, GPC	\$613
Pasta, individual portion cups	4 x 4 x 4-3/8	8030018	GPCRB, GPC, 8SMS, 8C	\$22
Pasta portion cup rack (holds 12 portion cups)	12-1/8 x 16-1/2 x 5-1/4	8030200	GPCRB, GPC	\$306
Pasta portion cup rack (holds 9 portion cups)	12-1/4 x 12-1/4 x 5-1/4	8030155	8SMS, 8C	\$228
Pasta support rack (for cookpot only)	17-1/4 x 22 x 3	8030205	GPCRB, GPC	\$187
Pasta support rack (for cookpot only)	15 x 18 x 3	8030167	8SMS, 8C	\$161
Pasta rinse tank screen	2 diameter face 1-1/4" diameter drain connection tail	8232022	GPCRB, 8SMS	\$93

NOTE:

• Any questions or pricing information other than above should be referred to **Customer Service -- Toll Free 1-800-221-4583.**

PRODUCT SPECIFICATIONS

Model Number	Description	Energy Requirements	Oil Capacity	Cooking Area Inches (cm) W x D X H	Width Inches (cm)	Depth Inches (cm)	Height Inches (cm)	Production Per Hr. (Full Frypot)	Cubic Feet Approx. Shipping Wt.
11814	Oil-Conserving Gas Fryer (without filter)	119,000 Btu/hr. (29,975 kcal) (34.9 kw)	63 lb. (31 liters)	18 x 14 x 3-3/4 (45.7 x 35.6 x 9.5)	20 (50.8)	33-1/8 (84.1)	47-3/4 (121.3)	100 lbs. Fries/hr.	40 255 lbs. (116 kg)
11814/ HD50G/11814	Oil-Conserving Gas Fryer (with filter)	11814 119,000 Btu/hr. (29,975 kcal) (34.9 kw) HD50G 100,000 Btu/hr. (25,189 kcal) (29.3 kw)	63 lb. (31 liters) per 11814 frypot & 50 lb. (25 liters)	18 x 14 x 3-3/4 (45.7 x 35.6 x 9.5) per 11814 frypot & 14 x 14 x 3-1/2 (35.6 x 35.6 x 8.9)	55-5/8 (141.3)	33-1/8 (84.1)	47-3/4 (121.3)	100 lbs. Fries/hr. per 11814 frypot 72 lbs. Fries/hr. per HD50G frypot	88 907 lbs. (411 kg)
FQG30U Series FQG30 Split Series	Filter Quick™ with Fingertip Filtration™ Oil-conserving Gas Fryers	75,000 Btu/hr. (18,892 kcal) (21.97 kw) 37,500 Btu/hr. (9,446 kcal) (10.98 kw) per split	30 lb. (15 liters) 17 lb. (8.5 liters)	13 x 14 x 3-3/4 (33 x 36 x 9.5) 6 x 14 x 3-1/2 (15 x 36 x 8.9)	31-1/4 (79.4)	29-7/8 (76)	46-1/2 (118)	67 lbs. Fries/hr.	52 544 lbs. (247 kg)
FPGL130 Series FPGL130 Split Series	OCF30 Oil-Conserving Gas Fryer (Full Frypot) OCF30 Oil-Conserving Gas Fryer (Split Frypot)	75,000 Btu/hr. (18,892 kcal) (21.97 kw) 37,500 Btu/hr. (9,446 kcal) (10.98 kw) per split	30 lb. (15 liters) 17 lb. (8.5 liters)	13 x 14 x 3-3/4 (33 x 36 x 9.5) 6 x 14 x 3-1/2 (15 x 36 x 8.9)	15-5/8 (39.7)	29-5/8 (75.3)	45-5/8 (115.8)	67 lbs. Fries/hr.	21 265 lbs. (120 kg)
FPGL230ATO Series FPGL230ATO Series Splits	OCF30 Oil-Conserving Gas Fryer (Full Frypot) with ATO OCF30 Oil-Conserving Gas Fryer (Split Frypot) with ATO	75,000 Btu/hr. (18,892 kcal) (21.97 kw) 37,500 Btu/hr. (9,446 kcal) (10.98 kw) per split	30 lb. (15 liters) 17 lb. (8.5 liters)	13 x 14 x 3-3/4 (33 x 36 x 9.5) 6 x 14 x 3-1/2 (15 x 36 x 8.9)	31-1/4 (79.4)	29-5/8 (75.3)	45-5/8 (115.8)	67 lbs. Fries/hr.	52 544 lbs. (247 kg)
ESG35T	Gas Value High Efficiency Fryer	70,000 Btu/hr. (17,632 kcal) (20.5 kw)	35 lb. (17 liters)	14 x 13-3/4 x 4-1/5 (35 x 34.9 x 10.7)	15-1/2 (39.4)	29-1/8 (74)	44 (111.8)	58 lbs. Fries/hr.	22 165 lbs. (75 kg)
HD50	Gas High Efficiency Fryer	100,000 Btu/hr. (25,189 kcal) (29.3 kw)	50 lbs. (25 liters)	14 x 14 x 3-1/2 (35 x 35 x 8.9)	15-1/2 (39.4)	31-1/4 (79.4)	45 (114.3)	72 lbs. Fries/hr.	22 180 lbs. (82 kg)
HD60	Gas High Efficiency Fryer	125,000 Btu/hr. (31,486 kcal) (36.6 kw)	80 lbs. (40 liters)	18 x 18 x 3-3/4 (46 x 46 x 9.5)	20 (50.8)	36-3/4 (93.4)	45 (114.3)	107 lbs. Fries/hr.	40 255 lbs. (116 kg)
LHD65	Gas, Low Flue Temperature Fryer	105,000 Btu/hr. (26,448 kcal) (30.8 kw)	100-lb. (50 liters)	18 x 18 x 5-3/4 (46 x 46 x 14.6)	20 (50.8)	36-1/2 (92.7)	43 (109.2)	128 pcs. bone-in chicken/hr.	72.9 260 lbs. (118 kg)
H55 H55-2	High Efficiency Gas Fryer (Full Frypot) High Efficiency Gas Fryer (Split Frypot)	80,000 Btu/hr. (20,151 kcal) (23.4 kw) 40,000 Btu/hr. (10,075 kcal) (11.7 kw) per split	50 lb. (25 liters) 25 lb. (12 liters)	14 x 15 x 4-1/2 (35.6 x 38.1 x 11.4) 6-1/2 x 15 x 4-3/4 (16.5 x 38.1 x 12.1)	15-5/8 (39.7)	29-5/8 (75.3)	45-5/8 (115.8)	68 lbs. Fries/hr.	21 202 lbs. (92 kg)
MJ45 MJ45-2	Gas Fryer (Full Frypot) Gas Fryer (Split Frypot)	122,000 Btu/hr. (30,730 kcal) (35.8 kw) 63,500 Btu/hr. (15,995 kcal) (18.6 kw) per split	50 lb. (25 liters) 25 lb. (12 liters)	14 x 15 x 5 (35.6 x 38.1 x 12.7) 7 x 15 x 4-3/4 (17.8 x 38.1 x 12.1)	15-5/8 (39.7)	31-1/2 (80.1)	46 (116.8)	69 lbs. Fries/hr.	21 202 lbs. (92 kg)
MJ35	Gas Fryer	110,000 Btu/hr. (27,700 kcal) (32.2 kw)	40 lb. (20 liters)	12 x 15 x 4-1/4 (30.5 x 38.1 x 10.8)	15-5/8 (39.7)	31-1/2 (80.1)	41 (104.1)	57 lbs. Fries/hr.	20 177 lbs. (80 kg)
MJCF/MJCFE	Gas Fryer	150,000 Btu/hr. (37,783 kcal) (44 kw)	80 lb. (40 liters)	18 x 19 x 4-1/2 (45.7 x 48.3 x 11.4)	20-7/8 (52.9)	39-7/8 (101.3)	46-1/8 (117.2)	80 lbs. chicken/hr. 100 lbs. fish/hr.	32 297 lbs. (135 kg)
GF40	Gas Fryer	122,000 Btu/hr. (30,730 kcal) (35.8 kw)	50 lb. (25 liters)	14 x 15 x 5 (35.6 x 38.1 x 12.7)	15-5/8 (39.7)	30-7/8 (78.3)	46-1/8 (117.1)	69 lbs. Fries/hr.	21 176 lbs. (80 kg)
GF14	Gas Fryer	100,000 Btu/hr. (25,189 kcal) (29.3 kw)	40 lb. (20 liters)	12 x 15 x 4 (30.5 x 38.1 x 10.2)	15-5/8 (39.7)	30-7/8 (78.3)	41-1/8 (104.4)	57 lbs. Fries/hr.	21 152 lbs. (69 kg)

PRODUCT SPECIFICATIONS -- CONTINUED

Model Number	Description	Energy Requirements	Oil Capacity	Cooking Area Inches (cm) W x D X H	Width Inches (cm)	Depth Inches (cm)	Height Inches (cm)	Production Per Hr. (Full Frypot)	Cubic Feet Approx. Shipping Wt.
11814E	Electric Oil-Conserving Fryer (without filter)	17 kw	60 lb. (30 liters)	18 x 14 x 4-1/4 (45.7 x 35.6 x 10.8)	20 (50.8)	30-7/8 (78.4)	45-3/8 (114.9)	83 lbs. Fries/hr.	40 255 lbs. (116 kg)
11814E/RE17/11814E	Electric Oil-Conserving Fryer (with filter)	17 kw per frypot	60 lb. (30 liters) per 1814 frypot & 50 lb. (25 liters)	18 x 14 x 4-1/4 (45.7 x 35.6 x 10.8) per frypot 14 x 14 x 3-1/2 (35.6 x 35.6 x 8.9)	56-1/4 (142.8)	30-7/8 (78.4)	45-3/8 (114.9)	83 lbs. Fries/hr. per 11814E frypot 70 lbs. Fries/hr. per RE17 frypot	89 907 lbs. (411 kg)
FQE30U Series FQE30U Series Splits	Filter Quick™ with Fingertip Filtration™ Oil-conserving Electric Fryers	14 kw	30 lb. (15 liters) 16 lb. (8 liters)	13 x 14 x 3-3/4 (33 x 36 x 9.5) 6 x 14 x 3-3/4 (15 x 36 x 9.5)	31-1/4 (79.4)	30-7/8 (78.6)	45-3/8 (115.2)	14 kw 71 lbs. Fries/hr.	52 544 lbs. (247 kg)
FPEL114 Series FPEL114 Series Splits	OCF30 Oil-Conserving Electric Fryer (Full Frypot) OCF30 Oil Conserving Electric Fryer (Split Frypot)	14 kw 7 kw per split	30 lb. (15 liters) 16 lb. (8 liters)	13 x 14 x 3-3/4 (33 x 36 x 9.5) 6 x 14 x 3-3/4 (15 x 36 x 9.5)	15-5/8 (39.7)	30-7/8 (78.6)	45-3/8 (115.2)	14 kw 71 lbs. Fries/hr.	21 255 lbs. (116 kg)
FPEL214 ATO Series FPEL214 ATO Series Splits	OCF30 Oil-Conserving Electric Fryer (Full Frypot) with ATO OCF30 Oil Conserving Electric Fryer (Split Frypot) with ATO	14 kw 7 kw per split	30 lb. (15 liters) 16 lb. (8 liters)	13 x 14 x 3-3/4 (33 x 36 x 9.5) 6 x 14 x 3-3/4 (15 x 36 x 9.5)	31-1/4 (79.4)	30-7/8 (78.6)	45-3/8 (115.2)	14 kw 71 lbs. Fries/hr.	52.5 535 lbs. (200 kg)
RE14TC/17TC/22TC RE14-2TC/17-2TC/22-2TC	Electric Fryer (Full Frypot) Electric Fryer (Split Frypot)	14/17/22 kw 7/8.5/11 kw per split	50 lb. (25 liters) 25 lb (12 liters)	14 x 15-1/2 x 3-3/4 (35.6 x 39.4 x 9.5) 6-3/4 x 15-1/2 x 3-3/4 (17.1 x 39.4 x 9.5)	15-5/8 (39.7)	31 (78.6)	45-3/8 (115.2)	70/74/77 lbs. (32/34/35 kg) Fries/hr.	21 190 lbs. (86 kg)
RE14/17/22 RE14-2/17-2/22-2	Electric Fryer (Full Frypot) Electric Fryer (Split Frypot)	14/17/22 kw 7/8.5/11 kw per split	50 lb. (25 liters) 25 lb. (12 liters)	14 x 15-1/2 x 3-1/2 (35.6 x 39.4 x 8.9) 6-3/4 x 15-1/2 x 3-1/2 (17.1 x 39.4 x 8.9)	15-5/8 (39.7)	31 (78.6)	45-3/8 (115.2)	68/70/76 lbs. (30/31/34 kg) Fries/hr.	21 190 lbs. (86 kg)
RE180	Electric Fryer	17 kw 21 kw	80 lb. (40 liters)	18 x 18 x 5 (45.7 x 45.7 x 12.7)	20 (50.8)	39-5/8 (100.6)	44-3/4 (113.7)	84 lbs. Fries/hr.	28 285 lbs. (129 kg)
PF95LP	Low Profile Portable Filter	120V/60 Hz 1 PH -6.2A	80 lb. (40 liters)	N/A	18-1/4 (46.4)	33-1/2 (85.2)	9-3/8 (23.9)	N/A	18 140 lbs. (67 kg)
PF50	Portable Filter	120V/60 Hz. 9 Amp	50 lb. (25 liters)	N/A	13-1/4 (33.7)	30 (76.2)	13-1/4 (33.7)	N/A	8 120 lbs. (54 kg)
PSDU50	Shortening Disposal Unit	N/A	50 lb. (25 liters)	N/A	15-3/8 (39)	32 (81.1)	48 (122.1)	N/A	10 62 lbs. (28 kg)
PSDU100	Shortening Disposal Unit	N/A	100 lb. (50 liters)	N/A	21 (53.3)	37-1/2 (95.3)	50 (127)	N/A	10 80 lbs (36 kg)
SHS 18	Sandwich Holding Station	208V 12A 2.5 kw	N/A	N/A	24" (61.0)	18-1/2" (47)	7-3/4" (19.6)	N/A	4.66 55 lbs. (25 kg)
SHS 22	Sandwich Holding Station	208V 12A 2.5 kw	N/A	N/A	24" (61.0)	22" (55.9)	7-3/4" (19.6)	N/A	5.06 65 lbs. (30 kg)
CDC50	Cleaning Solutions Caddy	N/A	50 lb. (25 liters)	N/A	11-1/2" (29.1)	23-1/8" (58.6)	31-3/4" (80.6)	N/A	7.63 120 lbs. (54 kg)

Frymaster, LLC, whose policy is one of constant improvement, reserves the right to amend specifications without prior notice.

DEAN PRODUCT SPECIFICATIONS

Model Number	Description	Energy Requirements	Oil Capacity lbs. (liter)	Cooking Area Inches (cm) W x D X H	Width Inches (cm)	Depth Inches (cm)	Overall Height Inches (cm)	Production Per Hr.	Cubic Feet Shipping Wt. lbs. (kg)
SM150G	Gas Fryer	120,000 Btu/hr. (30,600 kcal) (35.2 kw)	50 lbs. (25 liters)	14 x 14 x 3-1/2 (35 x 35 x 8.9)	15-1/2 (39.4)	30-3/4" (78)	46-1/8" (117)	60 lbs. Fries/hr.	22 180 (82)
SM5020G	Full/Half Size Gas Fryers	SM50: 120,000 Btu/hr. (30,600 kcal) (35.2 kw) SM20: 50,000 Btu/hr. (12,594 kcal) (14.6 kw)	50 lbs. (25 liters) 23 lbs. (12 liters)	14 x 14 x 3-1/2 (35 x 35 x 8.9) 6-3/4 x 14 x 3-7/8 (17 x 35 x 9.8)	23-1/4 (59.2)	29-1/4 (74.3)	45 (114.3)		40 295 (134)
SR42G	Economy Gas Fryer	105,000 Btu/hr. (26,481 kcal) (30.8 kw)	43 lbs. (21 liters)	14 x 13-3/4 x 4-1/5 (35 x 34.9 x 10.7)	15-1/2 (39.4)	29-1/4 (74.3)	45 (114.3)	57 lbs. Fries/hr.	22 150 (68)
SR62G	Economy Gas Fryer	150,000 Btu/hr. (37,783 kcal) (44 kw)	75 lbs. (37 liters)	18 x 18 x 3-3/4 (46 x 46 x 9.5)	20 (50.8)	35-1/2 (90.2)	45 (114.3)	86 lbs. Fries/hr.	22 255 (116)
D50G	Gas Fryer	120,000 Btu/hr. (30,600 kcal) (35.2 kw)	50 lbs. (25 liters)	14 x 14 x 3-1/2 (35 x 35 x 8.9)	15-1/2 (39.4)	31-1/4 (79.4)	45 (114.3)	63 lbs. Fries/hr.	22 180 (82)
D60G	Gas Fryer	150,000 Btu/hr. (37,783 kcal) (44 kw)	75 lbs. (37 liters)	18 x 18 x 3-3/4 (46 x 46 x 9.5)	20 (50.8)	36-1/2 (92.7)	45 (114.3)	92 lbs. Fries/hr.	40 255 (116)
SR14E	Economy Electric Fryer	14 kw	40 lbs. (20 liters)	13-3/4 x 13-3/4 x 5-1/4 (35 x 35 x 13.3)	15-3/4 (40)	27-1/4 (69)	44 (112)	56 lbs. Fries/hr.	21 180 (82)
MF90/80	Portable Oil Filter	120V/60 Hz 1 PH-6.2A	80 lbs. (40 liters)	N/A	18-1/4 (46)	24-3/4 (62.9)	24-1/8 (61)	N/A	8 120 (54)
MF90/80LP	Portable Oil Filter (Low Profile)	120V/60 Hz 1 PH-6.2A	80 lbs. (40 liters)	N/A	18 (46)	34-3/4 (88.3)	24 (61)	N/A	8 147 (66)
MF90/110	Portable Oil Filter	120V/60 Hz 1 PH -6.2A	110 lbs. (55 liters)	N/A	18-1/4 (46)	24-3/4 (62.9)	26-3/8 (67)	N/A	8 125 (56)
PSDU50	Shortening Disposal Unit	N/A	50 lbs. (25 liters)	N/A	15-3/8 (39)	32 (81.3)	48 (121.9)	N/A	7 62 (28)
PSDU100	Shortening Disposal Unit	N/A	100 lbs. (50 liters)	N/A	21 (53.3)	37-1/2 (95.3)	50 (127)	N/A	10 80 (36)

Specifications are for single frypot models. Additional specifications for multiple models are available at www.frymaster.com.

PASTA COOKER SPECIFICATIONS

Model Number	Description	Energy Requirements	Capacity	Cooking Area inches (cm) W x D X H	Width inches (cm)	Depth inches (cm)	Height inches (cm)	Cubic Feet Approx. Shipping Wt.
8SMS	Electric Pasta Cooker System (cooker and rinse tank)	8 kw	8-3/4 gal. (33.1 liters)	16 x 18-3/4 x 6-1/4 (40.6 x 47.6 x 16)	36 (91.4)	32-3/4 (83.2)	49 (124.5)	51 299 lbs. (136 kg)
8C	Single Electric Pasta Cooker	8 kw	8-3/4 gal. (33.1 liters)	16 x 18-3/4 x 6-1/4 (40.6 x 47.6 x 16)	18 (45.7)	31-3/8 (79.9)	40-1/2 (102.9)	21 192 lbs. (87 kg)
GPCRB	Gas Pasta Cooker with rinse tank, automatic timed basket lifter, auto-fill/skim, swing-away hot/cold rinse faucet	80,000 Btu/hr (20,151 kcal) (23.4 kw)	15 gal. (56.8 liters)	18 x 24 x 6-3/4 (45.7 x 61 x 17.2)	36 (91.4)	36-5/8 (93.0)	59 (149.9)	76 468 lbs (212 kg)
GPC	Gas Pasta Cooker with auto-fill/skim	80,000 Btu/hr (20,151 kcal) (23.4 kw)	15 gal. (56.8 liters)	18 x 24 x 6-3/4 (45.7 x 61 x 17.2)	20 (50.8)	33-5/8 (85.5)	45-5/8 (115.9)	23 331 lbs. (150 kg)

Frymaster, LLC, whose policy is one of constant improvement, reserves the right to amend specifications without prior notice.

DOMESTIC WARRANTY

WHAT IS COVERED

This warranty covers all defects in workmanship and material in all commercial cooking appliances and computer/controller equipment manufactured by Frymaster and sold within the domestic United States, except as excluded below.

WHO IS COVERED

This warranty covers only the original purchaser of Frymaster or Dean commercial cooking appliances and computer/controller equipment. This warranty is not transferable. You must have your original sales receipt for warranty coverage.

WHAT WE WILL DO

We will repair or replace the defective appliance, component or part. Such repair or replacement will be at the expense of Frymaster except that travel over 100 miles or two hours, overtime and holiday charges will be at the expense of the purchaser.

REPLACEMENT PARTS

- Parts, 90 days, no labor
- Mild steel frypot, 90 days, no labor
- Stainless Steel frypots, 1 year, 90 days labor
- Computers, 1 year, no labor

HOW TO GET SERVICE

Contact our Authorized Service Agent to obtain warranty service. To find the name and location of the nearest ASA call your dealer, or call the Frymaster Service Hotline, 1-800-551-8633. You can also go to the Frymaster website, www.frymaster.com, click on Service, click on Locator, key in zip code and it will give you the ASA for that zip code. When calling for service, please furnish the model number, serial number, series code number, voltage of your appliance, and a description of the problem. You must keep your sales receipt for proof of your date of purchase.

GAS				
	FRYPOT	FRYPOT & ASSEMBLY	CONTROLLERS	ALL OTHER PARTS
FILTER QUICK	N/A	7 years: parts & labor	1 year: parts & labor 2nd year: parts only	1 year: parts & labor 2nd year: parts only
OCF30 GAS	N/A	7 years: parts & labor	1 year: parts & labor 2nd year: parts only	1 year: parts & labor 2nd year: parts only
H55	N/A	7 years: parts & labor	1 year: parts & labor	1 year: parts & labor
1814 GAS	1st year: parts & labor 2nd- 10th years: part only	N/A	1 year: parts & labor	1 year: parts & labor
MJ35/MJ45/MJCF	4th year-Lifetime: part only	1st year: parts & labor 2nd & 3rd year: parts only	1 year: parts & labor	1 year: parts & labor
GF14/GF40	1st year: parts & labor 2nd- 5th years: part only	N/A	N/A	1 year: parts & labor
HD50/60	1st year: parts & labor 2nd- 10th years: part only	N/A	1 year: parts & labor	1 year: parts & labor
LHD65	1st year: parts & labor 2nd- 10th years: part only	N/A	1 year: parts & labor	1 year: parts & labor
D50/60	1st year: parts & labor 2nd- 10th years: part only	N/A	1 year: parts & labor	1 year: parts & labor
SM50	1st year: parts & labor 2nd- 10th years: part only	N/A	N/A	1 year: parts & labor
SR42/52/62	5 years: pro-rated*	N/A	N/A	1 year: parts & labor
ESG35T	5 years: pro-rated*	N/A	N/A	1 year: parts & labor

* 2nd year customer pays labor, freight and 20% of current frypot list price
3rd year customer pays labor, freight and 40% of current frypot list price
4th year customer pays labor, freight and 60% of current frypot list price
5th year customer pays labor, freight and 80% of current frypot list price

DOMESTIC WARRANTY(CONTINUED)

ELECTRIC				
	FRYPOT	FRYPOT & ASSEMBLY	CONTROLLERS	ALL OTHER PARTS
FILTER QUICK ELECTRIC	1st year: parts and labor 2nd year - Lifetime: part only	N/A	1 year: parts & labor 2nd year: parts only	1 year: parts & labor 2nd year: parts only
OCF30 ELECTRIC	1st year: parts and labor 2nd year - Lifetime: part only	N/A	1 year: parts & labor 2nd year: parts only	1 year: parts & labor 2nd year: parts only
1814E	1st year: parts and labor 2nd year - Lifetime: part only	N/A	1 year: parts & labor	1 year: parts & labor
RETC14/17/22	1st year: parts and labor 2nd year - Lifetime: part only	N/A	1 year: parts & labor	1 year: parts & labor
RE14/17/22	1st year: parts and labor 2nd year - Lifetime: part only	N/A	1 year: parts & labor	1 year: parts & labor
RE80	1st year: parts and labor 2nd year - Lifetime: part only	N/A	1 year: parts & labor	1 year: parts & labor

OTHER PRODUCTS			
	COOK POT & ASSEMBLY	COOK POT	ALL OTHER PARTS
SHORTENING DISPOSAL UNIT			90 days: Parts & Labor 91 days - 1 Year: Pump part only
GPC/GPCRB	1st year parts & labor 2nd year - 10 years: part only		1 year: parts & labor
8C/8SMS	N/A	1st year parts & labor 2nd year - 10 years: part only	1 year: parts & labor
FE155	1st year parts & labor 2nd year - 10 years: part only		1 year: parts & labor
SHS			1 year: parts & labor
PORTABLE FILTERS			1 year: parts & labor

WHAT THIS WARRANTY DOES NOT COVER

THE WARRANTIES PROVIDED BY FRYMASTER, LLC DO NOT APPLY IN THE FOLLOWING INSTANCES:

- Damage due to misuse, abuse, alteration, or accident.
- Improper or unauthorized repair.
- Failure to follow installation procedures, operation instructions and/or scheduled maintenance procedures as prescribed in your Frymaster or Dean Service and Owner's Manual.
- Damage in shipment.
- Removal, alteration, or obliteration of the rating plate.
- Changes in adjustment and calibrations after thirty (30) days from equipment installation date.
- Failure to program computer appliances in accordance with programming procedures prescribed in your Frymaster or Dean Service and Owner's Manual.
- Equipment exported to foreign countries.
- Normal maintenance items such as electric bulbs, fuses, gaskets, o-rings, interior and exterior finishes.
- Travel over 100 miles or two hours, overtime or holiday charges, all of which must be paid for by the purchaser.
- Consequential damages (the cost of repairing other property which is damaged), loss of time, profits, use or any other non-fryer related incidental damages of any kind.

GENERAL EXCLUSIONS

Warranty protection is only offered for fryers installed in accordance with the procedures described in the Frymaster or Dean Service and Owner's Manual.

There are no implied warranties of merchantability of fitness for any particular use or purpose. This warranty is the only and complete statement with respect to warranties of your commercial cooking appliances and computer/controller equipment manufactured by Frymaster. There are no other documents or oral statements for which Frymaster will be responsible.

LIMITED EXTENDED WARRANTY -- ELECTRIC

The purchase of a Limited Extended Warranty Contract extends the standard warranty coverage to the purchased period of time (from one to two years) from the date of installation, start-up or demonstration, or 18 months from date of shipment, whichever comes first. Individual warranties may vary by model, part or application. Major components have labor extended an additional year with the purchase of an extended warranty, but not parts. Extended warranties are non-transferable. Only available in the 48 contiguous US states (Hawaii and Alaska are excluded).

- An additional one (1) year Labor Warranty can be purchased for select pieces of Frymaster / Dean equipment.
- Extended Warranty must be purchased at the same time the equipment is purchased.
- Extended Warranty has the same exclusions as stated in our standard warranty.

ELECTRIC OCF30, FILTERQUICK AND OTHER FRYERS				
PRODUCT	SERVICE PURCHASED	PART NUMBER	ITEM DESCRIPTION	NET PRICE
1 Pot	No Discount	EW ELE FRYER1POT	+1YR WARRANTY ELECTRIC 1 POT FRYER	\$366.45
	Install Discount	EWI ELE FRYER1POT	+1YR WARRANTY ELECTRIC 1 POT FRYER INSTALL DISC	\$329.81
	PM Discount	EWP ELE FRYER1POT	+1YR WARRANTY ELECTRIC 1 POT FRYER PM DISCOUNT	\$293.16
	Install + PM Discount	EWIP ELE FRYER1POT	+1YR WARRANTY ELECTRIC 1 POT FRYER INSTALL+PM	\$256.52
2 Pot	No Discount	EW ELE FRYER2POT	+1YR WARRANTY ELECTRIC 2 POT FRYER	\$733.95
	Install Discount	EWI ELE FRYER2POT	+1YR WARRANTY ELECTRIC 2 POT FRYER INSTALL DISC	\$660.56
	PM Discount	EWP ELE FRYER2POT	+1YR WARRANTY ELECTRIC 2 POT FRYER PM DISCOUNT	\$587.16
	Install + PM Discount	EWIP ELE FRYER2POT	+1YR WARRANTY ELECTRIC 2 POT FRYER INSTALL+PM	\$513.77
3 Pot	No Discount	EW ELE FRYER3POT	+1YR WARRANTY ELECTRIC 3 POT FRYER	\$1,101.45
	Install Discount	EWI ELE FRYER3POT	+1YR WARRANTY ELECTRIC 3 POT FRYER INSTALL DISC	\$991.31
	PM Discount	EWP ELE FRYER3POT	+1YR WARRANTY ELECTRIC 3 POT FRYER PM DISCOUNT	\$881.16
	Install + PM Discount	EWIP ELE FRYER3POT	+1YR WARRANTY ELECTRIC 3 POT FRYER INSTALL+PM	\$771.02
4 Pot	No Discount	EW ELE FRYER4POT	+1YR WARRANTY ELECTRIC 4 POT FRYER	\$1,468.95
	Install Discount	EWI ELE FRYER4POT	+1YR WARRANTY ELECTRIC 4 POT FRYER INSTALL DISC	\$1,322.06
	PM Discount	EWP ELE FRYER4POT	+1YR WARRANTY ELECTRIC 4 POT FRYER PM DISCOUNT	\$1,175.16
	Install + PM Discount	EWIP ELE FRYER4POT	+1YR WARRANTY ELECTRIC 4 POT FRYER INSTALL+PM	\$1,028.27
5 Pot	No Discount	EW ELE FRYER5POT	+1YR WARRANTY ELECTRIC 5 POT FRYER	\$1,836.45
	Install Discount	EWI ELE FRYER5POT	+1YR WARRANTY ELECTRIC 5 POT FRYER INSTALL DISC	\$1,652.81
	PM Discount	EWP ELE FRYER5POT	+1YR WARRANTY ELECTRIC 5 POT FRYER PM DISCOUNT	\$1,469.16
	Install + PM Discount	EWIP ELE FRYER5POT	+1YR WARRANTY ELECTRIC 5 POT FRYER INSTALL+PM	\$1,285.52
6 Pot	No Discount	EW ELE FRYER6POT	+1YR WARRANTY ELECTRIC 6 POT FRYER	\$2,203.95
	Install Discount	EWI ELE FRYER6POT	+1YR WARRANTY ELECTRIC 6 POT FRYER INSTALL DISC	\$1,983.56
	PM Discount	EWP ELE FRYER6POT	+1YR WARRANTY ELECTRIC 6 POT FRYER PM DISCOUNT	\$1,763.16
	Install + PM Discount	EWIP ELE FRYER6POT	+1YR WARRANTY ELECTRIC 6 POT FRYER INSTALL+PM	\$1,542.77

LIMITED EXTENDED WARRANTY -- GAS

The purchase of a Limited Extended Warranty Contract extends the standard warranty coverage to the purchased period of time (from one to two years) from the date of installation, start-up or demonstration, or 18 months from date of shipment, whichever comes first. Individual warranties may vary by model, part or application. Major components have labor extended an additional year with the purchase of an extended warranty, but not parts. Extended warranties are non-transferable. Only available in the 48 contiguous US states (Hawaii and Alaska are excluded).

- An additional one (1) year Labor Warranty can be purchased for select pieces of Frymaster / Dean equipment.
- Extended Warranty must be purchased at the same time the equipment is purchased.
- Extended Warranty has the same exclusions as stated in our standard warranty.

GAS OCF30, FILTERQUICK AND OTHER FRYERS				
PRODUCT	SERVICE PURCHASED	PART NUMBER	ITEM DESCRIPTION	NET PRICE
1 Pot	No Discount	EW GAS FRYER1POT	+1YR WARRANTY GAS 1 POT FRYER	\$418.95
	Install Discount	EWI GAS FRYER1POT	+1YR WARRANTY GAS 1 POT FRYER INSTALL DISC	\$377.06
	PM Discount	EWP GAS FRYER1POT	+1YR WARRANTY GAS 1 POT FRYER PM DISCOUNT	\$335.16
	Install + PM Discount	EWIP GAS FRYER1POT	+1YR WARRANTY GAS 1 POT FRYER INSTALL+PM	\$293.27
2 Pot	No Discount	EW GAS FRYER2POT	+1YR WARRANTY GAS 2 POT FRYER	\$838.95
	Install Discount	EWI GAS FRYER2POT	+1YR WARRANTY GAS 2 POT FRYER INSTALL DISC	\$755.06
	PM Discount	EWP GAS FRYER2POT	+1YR WARRANTY GAS 2 POT FRYER PM DISCOUNT	\$671.16
	Install + PM Discount	EWIP GAS FRYER2POT	+1YR WARRANTY GAS 2 POT FRYER INSTALL+PM	\$587.27
3 Pot	No Discount	EW GAS FRYER3POT	+1YR WARRANTY ELECTRIC 3 POT FRYER	\$1,258.95
	Install Discount	EWI GAS FRYER3POT	+1YR WARRANTY GAS 3 POT FRYER INSTALL DISC	\$1,133.06
	PM Discount	EWP GAS FRYER3POT	+1YR WARRANTY GAS 3 POT FRYER PM DISCOUNT	\$1,007.16
	Install + PM Discount	EWIP GAS FRYER3POT	+1YR WARRANTY GAS 3 POT FRYER INSTALL+PM	\$881.27
4 Pot	No Discount	EW GAS FRYER4POT	+1YR WARRANTY ELECTRIC 4 POT FRYER	\$1,678.95
	Install Discount	EWI GAS FRYER4POT	+1YR WARRANTY GAS 4 POT FRYER INSTALL DISC	\$1,511.06
	PM Discount	EWP GAS FRYER4POT	+1YR WARRANTY GAS 4 POT FRYER PM DISCOUNT	\$1,343.16
	Install + PM Discount	EWIP GAS FRYER4POT	+1YR WARRANTY GAS 4 POT FRYER INSTALL+PM	\$1,175.27
5 Pot	No Discount	EW GAS FRYER5POT	+1YR WARRANTY ELECTRIC 5 POT FRYER	\$2,098.95
	Install Discount	EWI GAS FRYER5POT	+1YR WARRANTY GAS 5 POT FRYER INSTALL DISC	\$1,889.06
	PM Discount	EWP GAS FRYER5POT	+1YR WARRANTY GAS 5 POT FRYER PM DISCOUNT	\$1,679.16
	Install + PM Discount	EWIP GAS FRYER5POT	+1YR WARRANTY GAS 5 POT FRYER INSTALL+PM	\$1,469.27
6 Pot	No Discount	EW GAS FRYER6POT	+1YR WARRANTY ELECTRIC 6 POT FRYER	\$2,518.95
	Install Discount	EWI GAS FRYER6POT	+1YR WARRANTY GAS 6 POT FRYER INSTALL DISC	\$2,267.06
	PM Discount	EWP GAS FRYER6POT	+1YR WARRANTY GAS 6 POT FRYER PM DISCOUNT	\$2,015.16
	Install + PM Discount	EWIP GAS FRYER6POT	+1YR WARRANTY GAS 6 POT FRYER INSTALL+PM	\$1,763.27

KITCHEN CARE



By choosing Manitowoc Foodservice equipment made up of our leading brands, including Cleveland, Convotherm, Delfield, Frymaster, Garland, Kolpak, Lincoln, Manitowoc Ice, Merrychef, Multitplex, and Servend, you become part of our family. And you'll be glad to know we look after our own. That's what KitchenCare® is all about.

KitchenCare helps protect, service, and maintain your foodservice equipment throughout the lifecycle of your business. It's been developed with your needs in mind and structured around three levels of support: StarCare, ExtraCare, and LifeCare. KitchenCare is designed to give you choices in caring for your equipment, no matter if you have one restaurant or multi-unit operations. Whether you're around the world or just around the corner, our first responders are at the ready. You'll feel a level of comfort you've rarely felt in a business relationship, giving you the peace of mind that comes with knowing we'll get it right the first time.

Every new piece of Manitowoc Foodservice equipment comes with KitchenCare. Think of KitchenCare like a car warranty helping you optimize your kitchen. KitchenCare is your go-to mechanic. The expert you rely on to look after the technical details. The friendly face you talk to when you have everyday concerns. The one you trust to treat you right. Structured around levels of support to meet your operational needs from one restaurant to multiple units, you are able to choose the just the right level of support.

Use the link below to find a Factory Authorized Servicer in your area.

<http://www.manitowocfsusa.com/minisite/sales/buylocally>

Fryer Model Guide

Built-in Filtration	# of Fryers	# of Split Vats
FPP	1	-2 = 1 split vat
FP	2	-4 = 2 split vats
FM	3	-6 = 3 split vats
FMP	4	-8 = 4 split vats
CF	5	-10 = 5 split vats
SCF	6	

FPP H 2 55 - 2L BL C SC

Model Name:
H, RE, MJ, HD, SM, etc.

Model Number:
35, 45, 55, 14, 17, 40, 60, 80, etc.

Location of split vats:
L - Left side
R - Right side
M - Center

Cabinet Finishes:
SC - All s/s cabinet
SE - s/s door & cabinet ends

Basket Lift

CM3.5 or 3000 Controller

COMMON MODEL NUMBERS AND DESCRIPTIONS

MODEL	DESCRIPTION
21814NF	2 (# of frypots) 1814 (model name) N (natural gas) F (built-in filter)
SCFSM250GN	SCF (built-in filter) SM (model name) 2 (# of frypots) 50 (model #) G (gas) N (natural gas)
RE117SC	RE (model name) 1 (# of frypots) 17 (model #) SC (cabinet finish)
FPRE217SC	FP (built-in filter) RE (model name) 2 (# of frypots) 17 (model #) SC (cabinet finish)
FMRE214BLCSC	FM (built-in filter with spreader) RE (model name) 2 (# of frypots) 14 (model #) BL (basket lifts) C (CM3.5 controller) SC (cabinet finish)
FPRE217-4CSC	FP (built-in filter) RE (model name) 2 (# of frypots) 17 (model #) -4 (2 split frypots) C (CM3.5 controller) SC (cabinet finish)
FPEL414CA	FPEL (model name) 4 (# of frypots) 14 (model #) C (3000 controller) A (auto top-off)
FPGL230CA	FPGL (model name) 2 (# of frypots) 30 (model #) C (3000 controller) A (auto top-off)
FPGL230-2RBLC A	FPGL (model name) 2 (# of frypots) 30 (model #) -2 (1 split frypot) R (split on right) BL (basket lifts) C (3000 controller) A (auto top-of)
H155CSC	H (model name) 1 (# of frypots) 55 (model #) SC (cabinet finish)
FPH155SC	FP (built-in filter) H (model name) 1 (# of frypots) 55 (model #) SC (cabinet finish)
FPPH255CSC	FP (built-in filter) P (pro series cabinet) H (model name) 2 (# of frypots) 55 (model #) C (CM3.5 controller) SC (cabinet finish)
FPPH255-2RCSC	FPP (built-in filter) H (model name) 2 (# of frypots) 55 (model #) -2 (1 split frypot) R (split is on right) C (CM3.5 controller) SC (cabinet finish)
GF40SC	GF (model name) 40 (model#) SC (cabinet finish)
MJCFSC	MJCF (model name) SC (cabinet finish)
MJ145SC	MJ (model name) 1 (# of frypots) 45 (model#) SC (cabinet finish)
FPP245ECSC	FPP (built-in filter) 2 (# of frypots) 45 (MJ model #) E (electric hook-up) SC (cabinet finish)
CFD160GNT	CF (built-in filter) D (model name) 1 (# of frypots) 60 (model #) G (gas) N (natural gas) T (Thermatron controller)
SCFHD260GNC	SCF (built-in filter) HD (model name) 2 (# of frypots) 60 (model #) G (gas) N (natural gas) C (CM3.5 controller)
SR142GN	SR (model name) 1 (# of frypots) 42 (model #) G (gas) N (natural gas)
4FQG30U	4 (# of fryers) FQ (model name) G (gas) 30 (model number) U (open pot)

Scan the code below to locate a dealer, distributor or sales representative in your area.



Or go to
www.manitowocfsusa.com/minisite/sales/buylocally



COMPANY WITH
QUALITY SYSTEM
CERTIFIED BY DNV
= ISO 9001:2008 =

Manitowoc Foodservice is a global leader in foodservice operations that speaks the language of our partners from sales to aftercare. Purchasing equipment is easy with Manitowoc Finance, which offers direct, low-rate financing options for the equipment you need today. Manitowoc KitchenCare® helps service, maintain, and protect your foodservice equipment and facility throughout the lifecycle of your business. Being fluent is more than understanding equipment; it is an understanding of your foodservice business. If you're ready to talk foodservice, Manitowoc speaks your language.

Our best in class brands include: Cleveland, Convotherm®, Dean®, Delfield®, Frymaster®, Garland®, Kolpak®, Koolaire®, Kysor Panel Systems®, Lincoln, Manitowoc® Beverage Systems, Manitowoc® Ice, Merco®, Merrychef®, Multiplex®, RDI Systems, Servend®, U.S. Range & Welbilt®



Fluent in Foodservice | mtwfs.com